

# BAS-311H

パーツブック  
PARTS BOOK

ダイレクトドライブ  
プログラム式電子ミシン

DIRECT DRIVE  
PROGRAMMABLE ELECTRONIC PATTERN SEWER

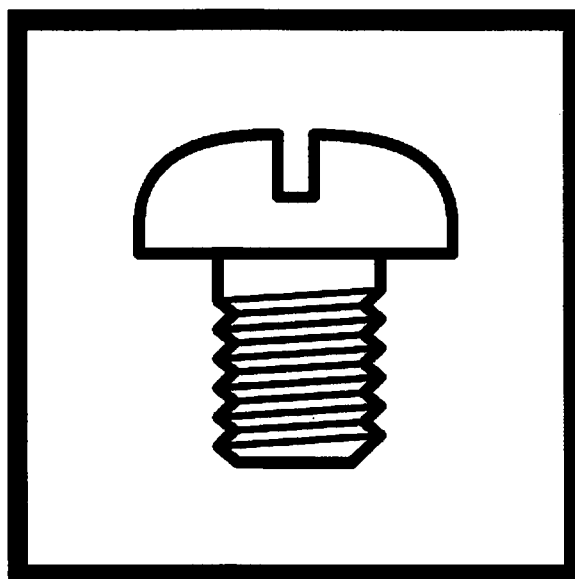

**brother**<sup>®</sup>

最新の部品情報は Parts Navigation でご覧いただけます。  
The latest parts information, refer to the Parts Navigation.

<http://partsbook.brother.co.jp/partsnavi/jpn/>  
<http://partsbook.brother.co.jp/partsnavi/eng/>

## 型式板の見方

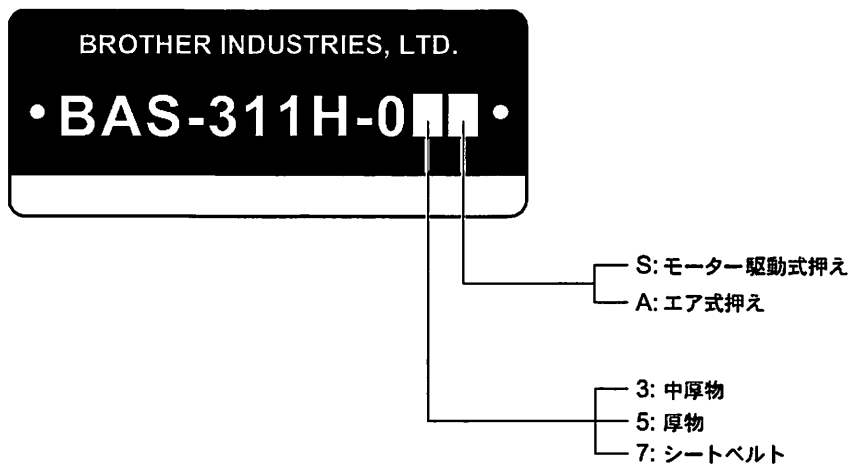

# Description of model plate

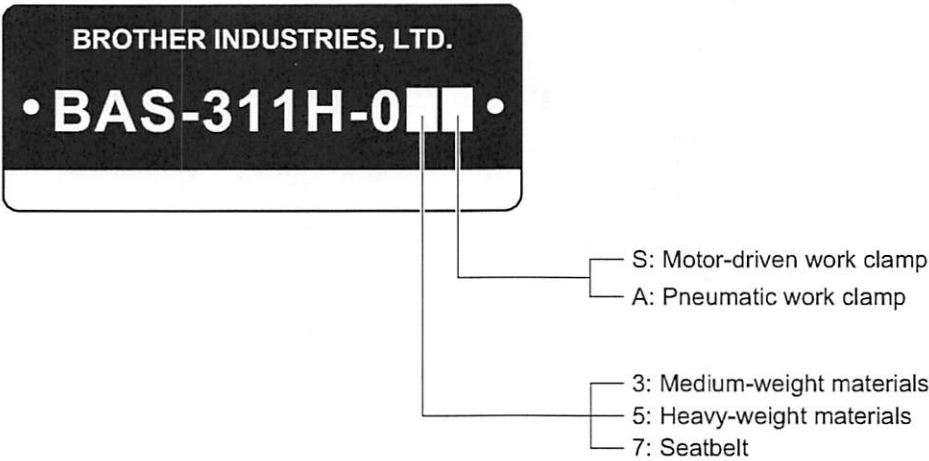

## パーツブックご利用に際して

1. この本は、2013年6月のデータに基づいて作成されたものです。
2. 部品は予告なしに設計変更される場合があります。
3. 組単位で補給する部品は、破線で示してあります。
4. イラスト中で数字(REF.NO)に“+”がついている部品は、仕様により異なります。詳細は、リストを参照してください。

### 目 次

A. 主体関係 .....	1
B. 上軸・針棒関係 .....	3
C1. 送り関係 .....	5
C2. 送り関係 .....	7
C3. 送り関係 .....	9
C4. 送り関係(-0□S) .....	11
C5. 送り関係(-0□A) .....	13
C6. 送り関係(オプション部品) .....	15
D1. 押え上げ関係 .....	17
D2. 押え上げ関係(-0□S) .....	19
D3. 押え上げ関係(-0□A) .....	21
E. 下軸関係 .....	23
F. 給油潤滑関係 .....	25
G. 糸通し関係 .....	27
H. 糸巻関係 .....	29
J. 糸切り関係 .....	31
K. 糸払い関係 .....	35
L. 糸緩め関係 .....	37
M1. コントロールボックス関係 .....	39
M2. コントロールボックス関係 .....	41
N. 空圧関係(-0□A) .....	43
P. 電装品関係 .....	45
Q. モーター・操作パネル関係 .....	47
R. 踏板関係(オプション部品) .....	49
S. プログラム関係 .....	51
T1. 付属装置関係(オプション部品) .....	53
T2. 付属装置関係(オプション部品) .....	55
T3. 付属装置関係(オプション部品) .....	57
T4. 付属装置関係(オプション部品) .....	59
Z. 付属品関係 .....	61
Wa. 警告ラベル .....	65
Sp. 仕様別部品一覧表 .....	67
Ga. ゲージ部品一覧表 .....	69
索引 .....	70

## Notes for using this parts book

1. This book was prepared based on information available in June 2013.
2. Parts are subject to changes in design without prior notice.
3. Parts supplied as complete assemblies are circled by a dotted line.
4. The part which has the symbol "+" on its number (REF.NO) in the figure differs depending on the specification. For details, refer to the parts list.

### CONTENTS

A. Machine body .....	1
B. Upper shaft and needle bar mechanism .....	3
C1. Feed mechanism .....	5
C2. Feed mechanism .....	7
C3. Feed mechanism .....	9
C4. Feed mechanism (-0[S]) .....	11
C5. Feed mechanism (-0[A]) .....	13
C6. Feed mechanism (Option parts) .....	15
D1. Work clamp lifter mechanism .....	17
D2. Work clamp lifter mechanism (-0[S]) .....	19
D3. Work clamp lifter mechanism (-0[A]) .....	21
E. Lower shaft mechanism .....	23
F. Lubrication .....	25
G. Threading mechanism .....	27
H. Bobbin winder mechanism .....	29
J. Thread trimmer mechanism .....	31
K. Thread wiper mechanism .....	35
L. Tension release mechanism .....	37
M1. Control box .....	39
M2. Control box .....	41
N. Air pressure mechanism (-0[A]) .....	43
P. Power supply equipment .....	45
Q. Motor mechanism and operation panel .....	47
R. Foot switch pedal mechanism (Option parts) .....	49
S. Programmer .....	51
T1. Attachment set (Option parts) .....	53
T2. Attachment set (Option parts) .....	55
T3. Attachment set (Option parts) .....	57
T4. Attachment set (Option parts) .....	59
Z. Accessories .....	61
Wa. Warning labels .....	65
Sp. Different parts list .....	67
Ga. Gauge parts list .....	69
Index .....	70

A. 主体関係 / Machine body

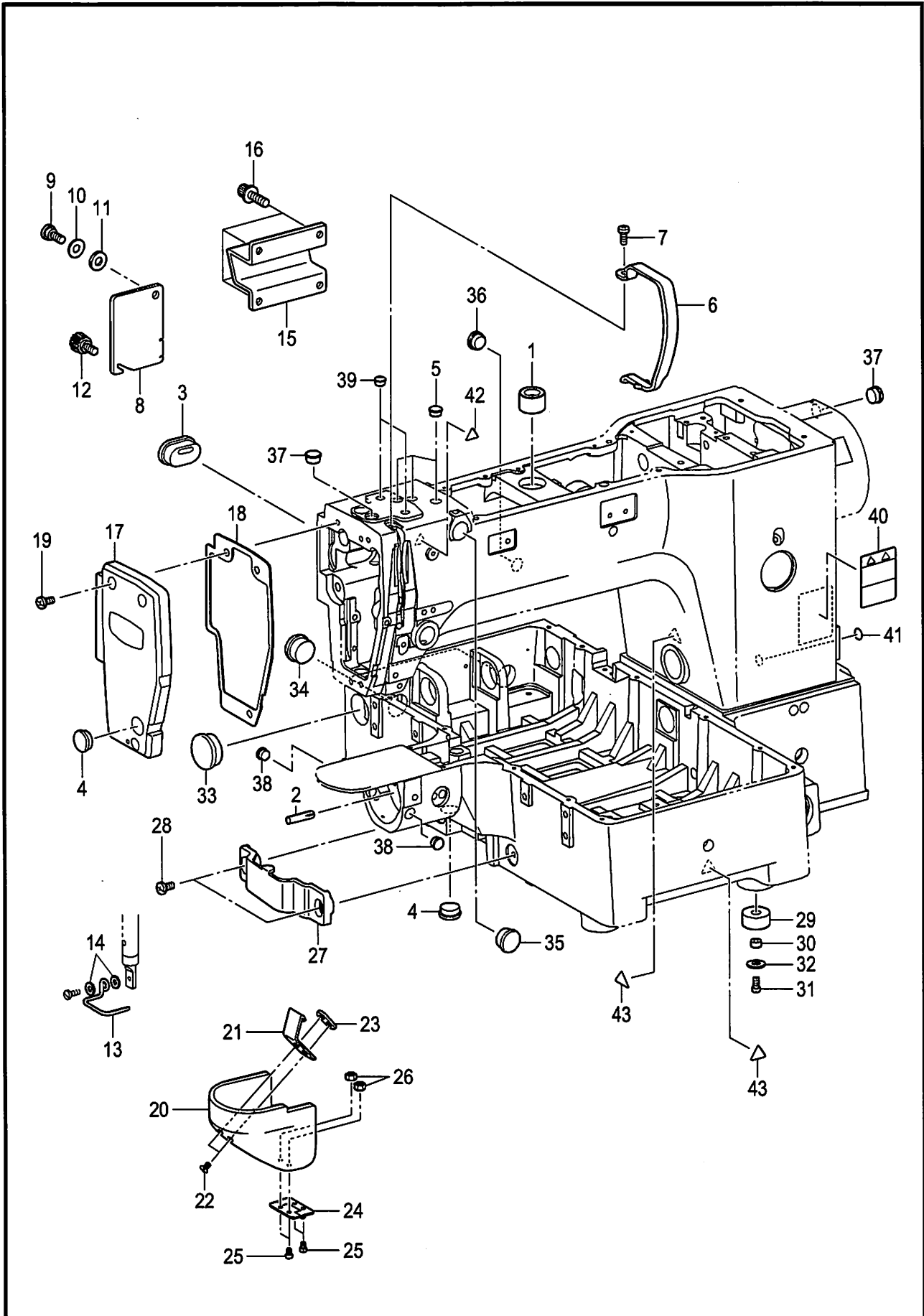

BAS-311H-050

## A. 主体関係 / Machine body

REF.NO	CODE	Q'TY	品名	NAME OF PARTS	RM
1	SA4594001	1	オサエアゲメタルU	BUSHING U	
2	117608001	1	ミゾツキピン	DOWEL PIN	
3	SA4596001	1	ゴムセン20-15	RUBBER CAP 20-15	
4	104449001	2	ゴムセン15.5	RUBBER CAP, 15.5	
5	104821001	3	ゴムセン10.5	RUBBER CAP, 10.5	
6	SB1277001	1	テンビンカバー	THREAD TAKE-UP LEVER COVER	
7	062401016	1	ナベコ4X10	SCREW PAN M4X10	
8	SA4604101	1	カンケツカバー	STEPPING COVER	
9	SA3306001	1	ダンネジ7-3	SHOULDER SCREW,7-3	
10	120265002	1	ナミバネザガネ	SPRING WASHER	
11	S07350002	1	ザガネ	WASHER PLAIN	
12	S36475000	1	ツマミネジM5	SCREW, M5	
13	SA8679001	1	フィンガーガード	FINGER GUARD	
14	SB2456001	2	ヒラザガネダイ3.5	WASHER PLAIN 3.5	
15	SA4605001	1	マクラ	HEAD REST	
16	S42446001	4	アナボルトザクミ6X14	BOLT SOCKET (S/P WASHER)M6X14	
17	SA4600002	1	メンイタ	FACE PLATE	
18	SA4601001	1	メンイタパッキン	F-PLATE PACKING	
19	062061016	3	ナベコ6X10	SCREW PAN M6X10	
20	SA4603102	1	オオカマカバー	SHUTTLE RACE COVER	
21	SA6272001	1	オオカマカバーフックD	SHUTTLE RACE COVER HOOK D	
22	004300513	2	+サラコ3X5	SCREW, FLAT M3X5	
23	SA3264101	1	イタナツト	NUT PLATE	
24	SA6207001	1	チヨウバン	HINGE	
25	062300506	4	ナベコ3X5	SCREW PAN M3X5	
26	021300103	2	1シュナツト3	NUT, 1 M3	
27	SB4413001	1	イトキリカバー	THREAD TRIMMER COVER	
28	062501216	2	ナベコ5X12	SCREW PAN M5X12	
29	SB4385001	6	クッションゴム	RUBBER CUSHION	
30	SB4384001	6	カラ-	COLLAR	
31	062401016	6	ナベコ4X10	SCREW PAN M4X10	
32	025040136	6	ヒラザガネショウ4	WASHER PLAIN S 4	
33	159163000	1	ゴムセン29	RUBBER CAP 29	
34	159150000	2	ゴムセン20.5	RUBBER CAP, 20.5	
35	S23337001	1	ゴムセン18.5	RUBBER CAP, 18.5	
36	104449001	1	ゴムセン15.5	RUBBER CAP, 15.5	
37	S20164001	2	ゴムセン13	RUBBER CAP, 13	
38	S44010001	2	ゴムセン11.5	RUBBER CAP, 11.5	
39	104450101	2	ゴムセン8	RUBBER CAP, 8	
40	SA9826001	1	ソウサチュウイラベル	LABEL CAUTION	
41	S37060001	1	ア-スマーク	LABEL, GROUNDING	
42	SA9957001	1	ワ-ニングマーク	INJURY MARK	
43	SA9957002	2	ワ-ニングマーク	INJURY MARK	

BAS-311H-050

B. 上軸・針棒関係 / Upper shaft and needle bar mechanism

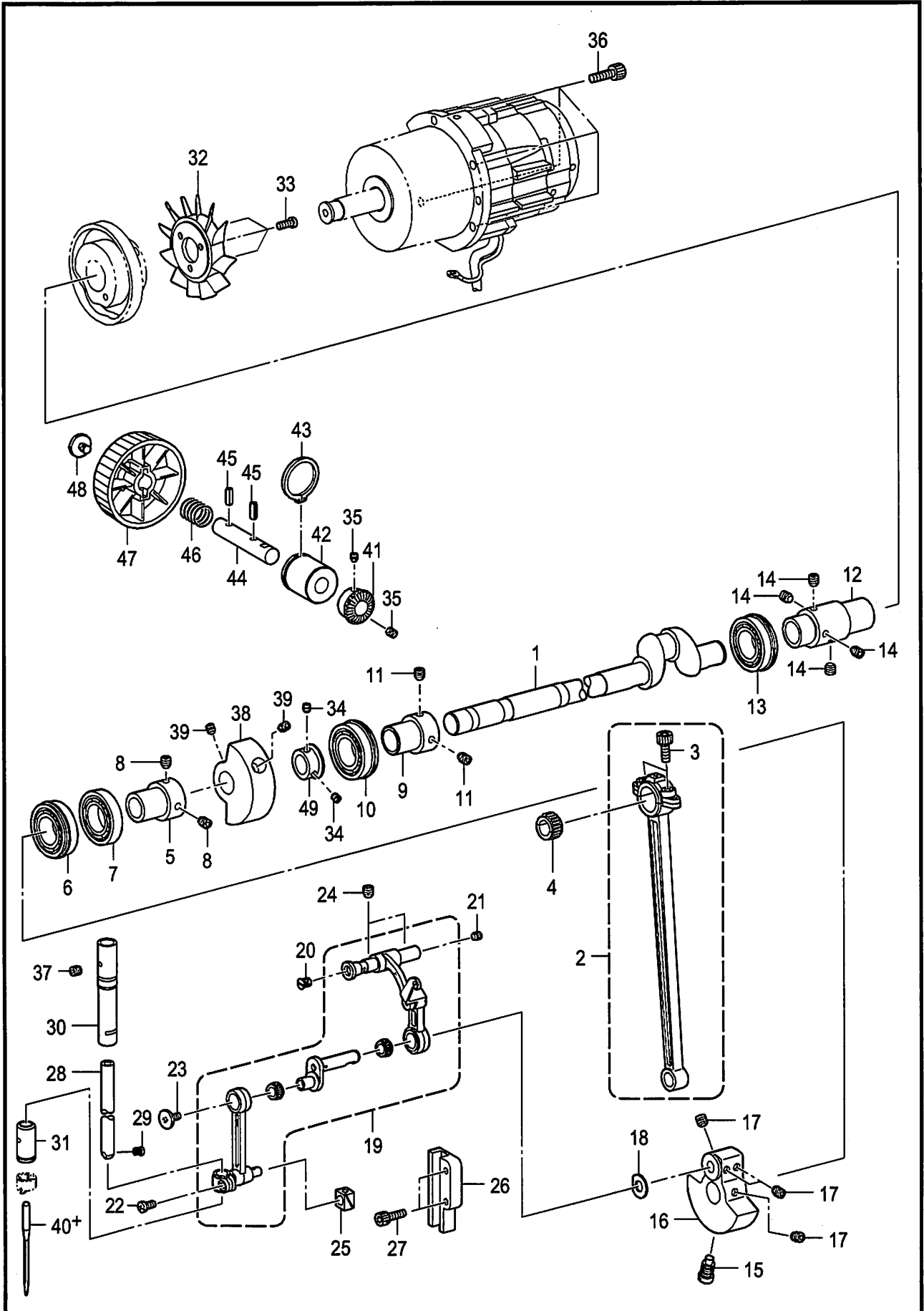

BAS-311H-123



B. 上軸・針棒関係 / Upper shaft and needle bar mechanism

REF.NO	CODE	QTY	品名	NAME OF PARTS	RM
1	SA4606201	1	ウワジク	UPPER SHAFT	
2	SA3499001	1	クランクロッドクミ	CRANK ROD ASSY	
3	018501636	2	アナボルト5X16	BOLT SOCKET M5X16	
4	SA4172001	1	ニードルベアリング: 青色	NEEDLE BEARING: BLUE	
4	SA4173001	1	ニードルベアリング: 黒色	NEEDLE BEARING: BLACK	
4	SA4174001	1	ニードルベアリング: 灰色	NEEDLE BEARING: GRAY	
4	SA4175001	1	ニードルベアリング: 黄色	NEEDLE BEARING: YELLOW	
5	SA3206001	1	ベアリングブッシュ	BALL BEARING BUSH	
6	SA4179001	1	タマジクウケ6904DDUNR	BALL BEARING 6904DDUNR	
7	SA4180001	1	タマジクウケ6904DDU	BALL BEARING 6904DDU	
8	S23651001	2	アナヒラ6X6ホソメ	SET SCREW, SOCKET (FT) M6X6	
9	SA3206001	1	ベアリングブッシュ	BALL BEARING BUSH	
10	SA4177001	1	タマジクウケ6004DDUNR	BALL BEARING 6004DDUNR	
11	S23651001	2	アナヒラ6X6ホソメ	SET SCREW, SOCKET (FT) M6X6	
12	SA4608101	1	ツギテG	JOINT G	
13	SA4178001	1	タマジクウケ6204DDUNR	BALL BEARING 6204DDUNR	
14	S23651001	4	アナヒラ6X6ホソメ	SET SCREW, SOCKET (FT) M6X6	
15	S25235001	1	シメネジ8	SCREW, M8	
16	SA4609101	1	ツリアイクランクG	THREAD TAKE-UP CRANK G	
17	S23651001	4	アナヒラ6X6ホソメ	SET SCREW, SOCKET (FT) M6X6	
18	110367001	1	ザガネ	WASHER, PLAIN SPECIAL 8	
19	SA6182001	1	ハリボウレンカンFKクミ	THREAD TAKE-UP LEVER FK SET	
20	SA2958001	1	サラネジ5X6	SCREW FLAT M5X6	
21	012500536	1	アナヒラ5X5	SET SCREW SOCKET (FT) M5X5	
22	062400816	1	ナベコ4X8	SCREW PAN M4X8	
23	145465001	1	シメネジ3.57L	SCREW, SM3.57-40X6 L	
24	012060636	2	アナヒラ6X6	SET SCREW SOCKET (FT) M6X6	
25	142211001	1	カクコマ	SLIDE BLOCK	
26	SA3528001	1	カクコマアンナイB	SLIDE BLOCK GUIDE	
27	018401636	2	アナボルト4X16	BOLT SOCKET M4X16	
28	SA4622001	1	ハリボウ	NEEDLE BAR	
29	144458001	1	アタマツキトメネジ3.57	SET SCREW, SM3.57-40X4.5	
30	SA4666001	1	ハリボウメタルUK	NEEDLE BAR BUSH UK	
31	SA3224001	1	ハリボウメタルD	NEEDLE BAR BUSH, D	
32	S38713100	1	ファン	FAN	
33	062400816	3	ナベコ4X8	SCREW PAN M4X8	
34	012500536	2	アナヒラ5X5	SET SCREW SOCKET (FT) M5X5	
35	012500536	2	アナヒラ5X5	SET SCREW SOCKET (FT) M5X5	
36	018501636	4	アナボルト5X16	BOLT SOCKET M5X16	
37	012060536	1	アナヒラ6X5	SET SCREW SOCKET (FT) M6X5	
38	SA4797101	1	イトマキドウリン	DRIVING WHEEL B-WINDER	
39	S23651001	2	アナヒラ6X6ホソメ	SET SCREW, SOCKET (FT) M6X6	
40+			<-03□用> ミシンハリ DPX5…(#16)	<For -03□> NEEDLE DPX5…(#16)	
40+			<-05□用> ミシンハリ DPX17…(#19)	<For -05□> NEEDLE DPX17…(#19)	
40+			<-07□用> ミシンハリ DPX17…(#25)	<For -07□> NEEDLE DPX17…(#25)	
41	SB1039001	1	プーリギヤL	PULLEY GEAR L	
42	SB1038001	1	プーリメタル	PULLEY BUSH	
43	048280142	1	トメワジクヨウC28	RETAINING RING EXTERNAL C28	
44	SB2097001	1	プーリジク	PULLEY SHAFT	
45	047402042	2	スプリングピンAW4	PIN SPRING ROLL AW4	
46	SB1041001	1	プーリバネ	PULLEY SPRING	
47	SB0910201	1	プーリ	PULLEY	
48	SB1040001	1	プーリネジ	SCREW	
49	SA9004001	1	プーリギヤR	PULLEY GEAR R	

BAS-311H-123

C1. 送り関係 / Feed mechanism

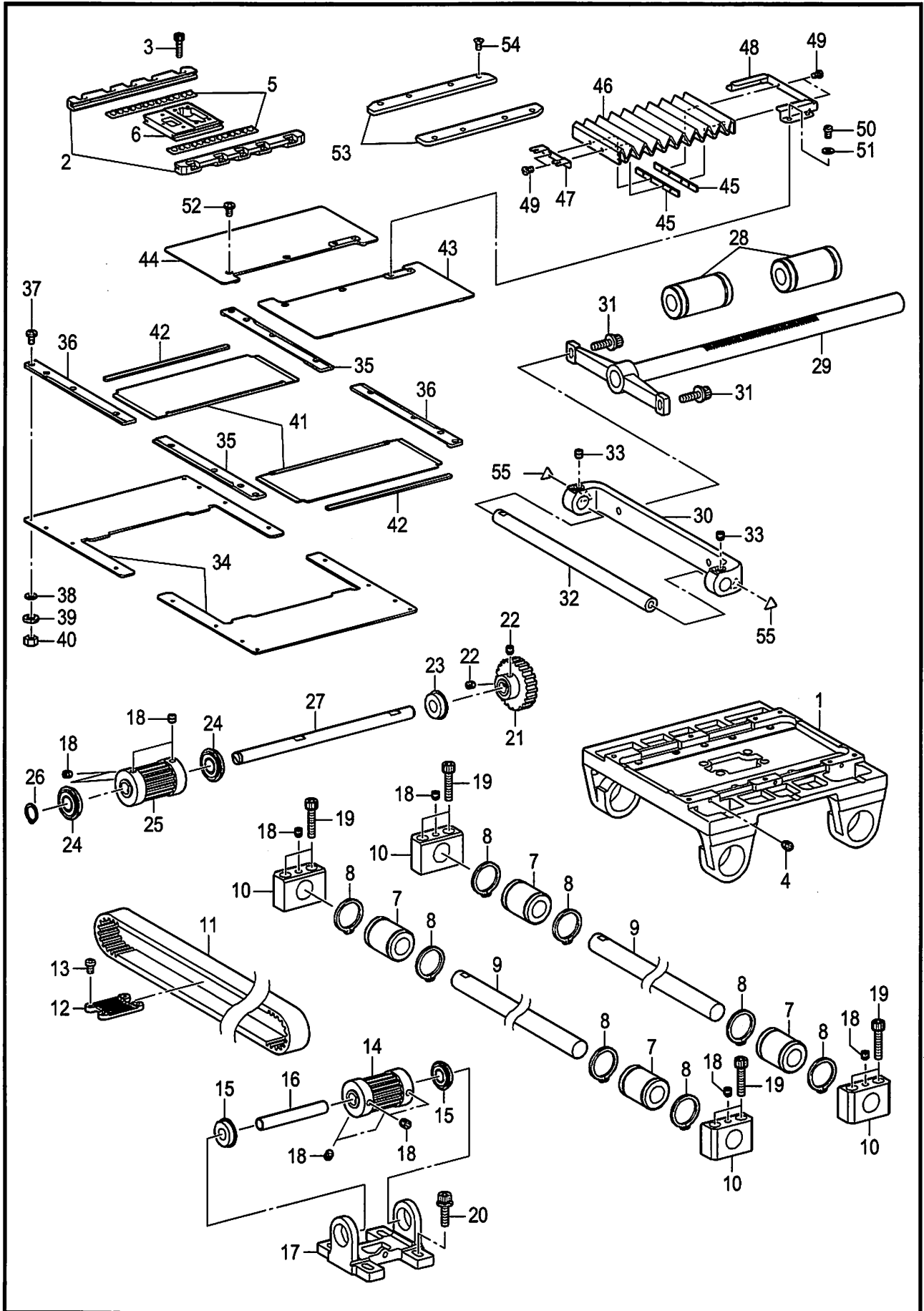

BAS-311H-202

## C1. 送り関係 / Feed mechanism

REF.NO	CODE	Q'TY	品名	NAME OF PARTS	RM
1	SB4344101	1	オクリダイコクミ	X-FEED BRACKET S ASSY	
2	SB4186201	2	Yオクリアンナイ	Y-FEED GUIDE	
3	018501036	10	アナボルト5X10	BOLT SOCKET M5X10	
4	012400636	6	アナヒラ4X6	SET SCREW SOCKET (FT) M4X6	
5	SB4430001	2	クロスローラ	CLOTH ROLL	
6	SB4185301	1	Yオクリダイ	Y-FEED BASE	
7	SA5593001	4	ボールブツシュ	LINEAR BUSH 16	
8	SB4351001	8	トメワジクヨウC28	RETAINING RING EXTERNAL C28	
9	SB4184001	2	Xオクリジク	X SHAFT	
10	SB4402001	4	Xオクリジクホルダ	X-FEED SHAFT HOLDER	
11	SB4432001	1	タイミングベルト	TIMING BELT	
12	SB4341001	1	ベルトオサエイタ	BELT WORK CLAMP PLATE	
13	062400816	4	ナベコ4X8	SCREW PAN M4X8	
14	SB4406001	1	タイミングプーリ	TIMING PULLEY	
15	SA4647001	2	タマジクウケ6900ZZNR	BALL BEARING 6900ZZNR	
16	SB4339001	1	Xプーリシテンジク	X-PULLEY FULCRUM SHAFT	
17	SB4340001	1	Xプーリブラケット	X-PULLEY BRACKET	
18	012060636	8	アナヒラ6X6	SET SCREW SOCKET (FT) M6X6	
19	018063036	8	アナボルト6X30	BOLT SOCKET M6X30	
20	SA2972001	4	アナボルトザクミ6X18	BOLT SOCKET(S/P WASHER)M6X18	
21	SB4282001	1	Xオクリギア	X-FEED GEAR	
22	012060636	6	アナヒラ6X6	SET SCREW SOCKET (FT) M6X6	
23	SA4647001	1	タマジクウケ6900ZZNR	BALL BEARING 6900ZZNR	
24	SB4469001	2	タマジクウケ6000ZZNR	BALL BEARING 6000ZZNR	
25	SB4406001	1	タイミングプーリ	TIMING PULLEY	
26	048100142	1	トメワジクヨウC10	RETAINING RING EXTERNAL C10	
27	SB4338001	1	Xプーリドウジク	X-PULLEY DRIVING SHAFT	
28	SB4431001	2	ボールブシュ	BALL BUSH	
29	SB4281001	1	Yラックジククミ	Y-RACK SHAFT ASSY	
30	SB4337001	1	Xオクリジクササエ	X-FEED SHAFT SUPPORT	
31	S42446001	2	アナボルトザクミ6X14	BOLT SOCKET (S/P WASHER)M6X14	
32	SB4335001	1	Xオクリジク	X-FEED SHAFT	
33	012060636	2	アナヒラ6X6	SET SCREW SOCKET (FT) M6X6	
34	SB4366001	2	コテイカバー	FIXATION COVER	
35	SB4357001	2	カバーレールR	COVER RAIL R	
36	SB4356001	2	カバーレールL	COVER RAIL L	
37	SA3538001	16	シメネジ4X8	SCREW,M4X8	
38	SB3848001	4	ヒラザガネチュウ4	WASHER_PLAIN_M_4	
39	028040246	4	バネザガネ2-4	WASHER SPRING 2-4	
40	021400216	4	2シュナット4	NUT 2 M4	
41	SB4360001	2	ソトカバー	OUTSIDE COVER	
42	SA6358101	2	ソトカバーゴム	OUTSIDE COVER RUBBER	
43	SB4358001	1	ウチカバーR	INSIDE COVER R	
44	SB4359001	1	ウチカバーL	INSIDE COVER L	
45	SB4362001	2	ジャバラナット	BELLOW NUT	
46	SB4363001	1	ジャバラ	BERROW	
47	SB4365101	1	ジャバラオサエF	BELLOW PRESSER F	
48	SB4361001	1	ジャバラオサエR	BELLOW PRESSER R	
49	062300416	4	ナベコ3X4	SCREW PAN M3X4	
50	062401216	4	ナベコ4X12	SCREW PAN M4X12	
51	SB3848001	4	ヒラザガネチュウ4	WASHER_PLAIN_M_4	
52	SA3538001	4	シメネジ4X8	SCREW,M4X8	
53	SB4689201	2	Yオクリアンナイカバー	Y-FEED GUIDE COVER	
54	SA6308001	8	0サラコ3シュ2X4	SCREW FLAT #0 M2X4	
55	SA9957001	2	ワ-ニングマーク	INJURY MARK	

BAS-311H-202

C2. 送り関係 / Feed mechanism

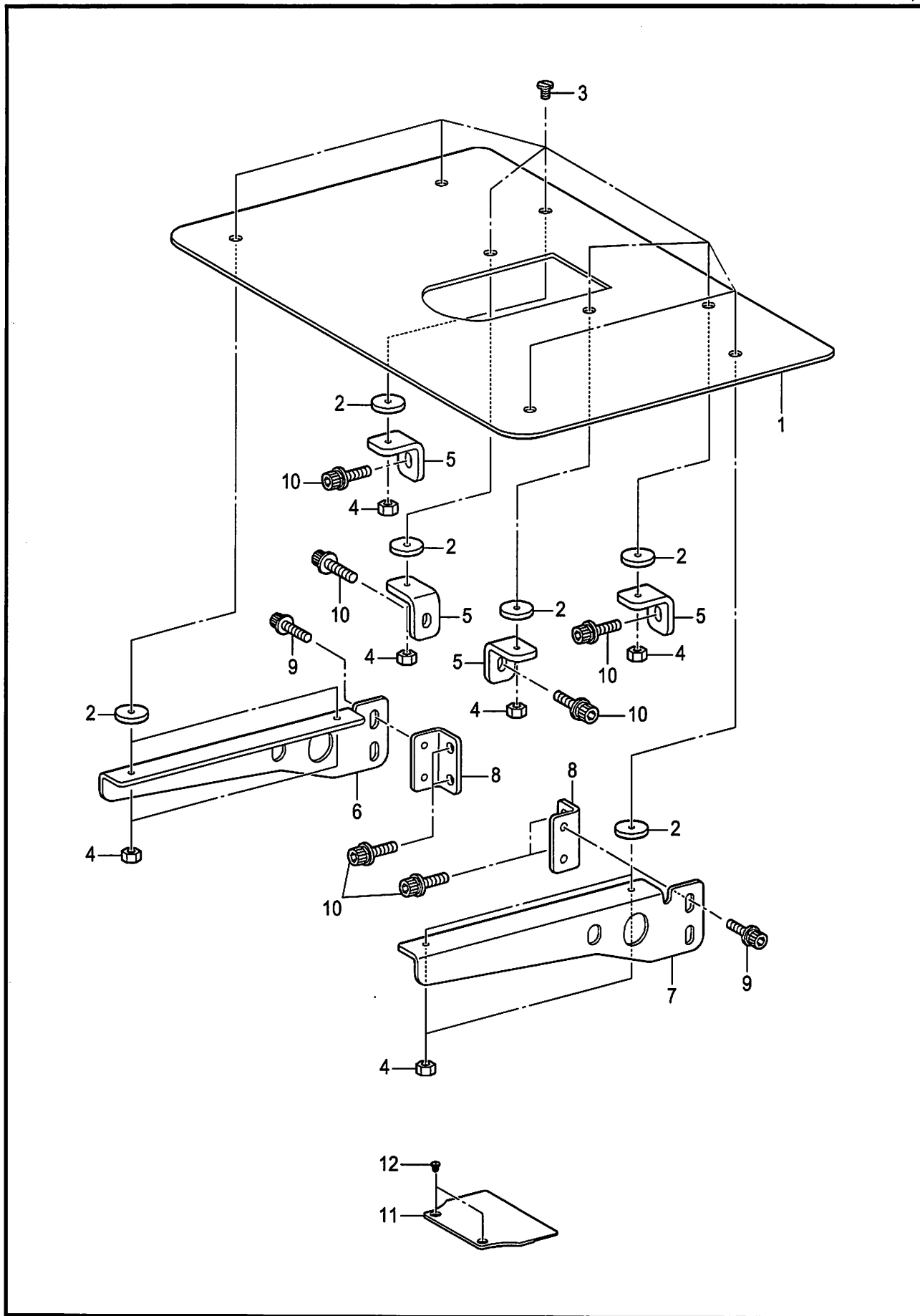

BAS-311H-202

## C2. 送り関係 / Feed mechanism

REF.NO	CODE	Q'TY	品名	NAME OF PARTS	RM
1	SB4183001	1	ハリイタホジョイタ	AUXILIARY PLATE	
2	SA4677101	8	ホジョイタクッション	AUXILIARY PLATE CUSHION	
3	SA8560001	8	シメネジ4X12	SCREW M4X12	
4	021400216	8	2シュナット4	NUT 2 M4	
5	SA4676201	4	ホジョイタブラケット	AUXILIARY PLATE BRACKET	
6	SB4407001	1	ホジョイタブラケットL	AUXILIARY PLATE BRACKET L	
7	SB4408001	1	ホジョイタブラケットR	AUXILIARY PLATE BRACKET R	
8	SB4409001	2	ホジョイタブラケットM	AUXILIARY PLATE BRACKET M	
9	S55484001	4	アナボルトザクミ5X10	BOLT SOCKET (S/P WASHER)M5X10	
10	S42446001	8	アナボルトザクミ6X14	BOLT SOCKET (S/P WASHER)M6X14	
11	SA6594001	1	ショートハリイタホジョイタ	SHORT AUXILIARY PLATE	
12	SA3538001	2	シメネジ4X8	SCREW,M4X8	

BAS-311H-202

C3. 送り関係 / Feed mechanism

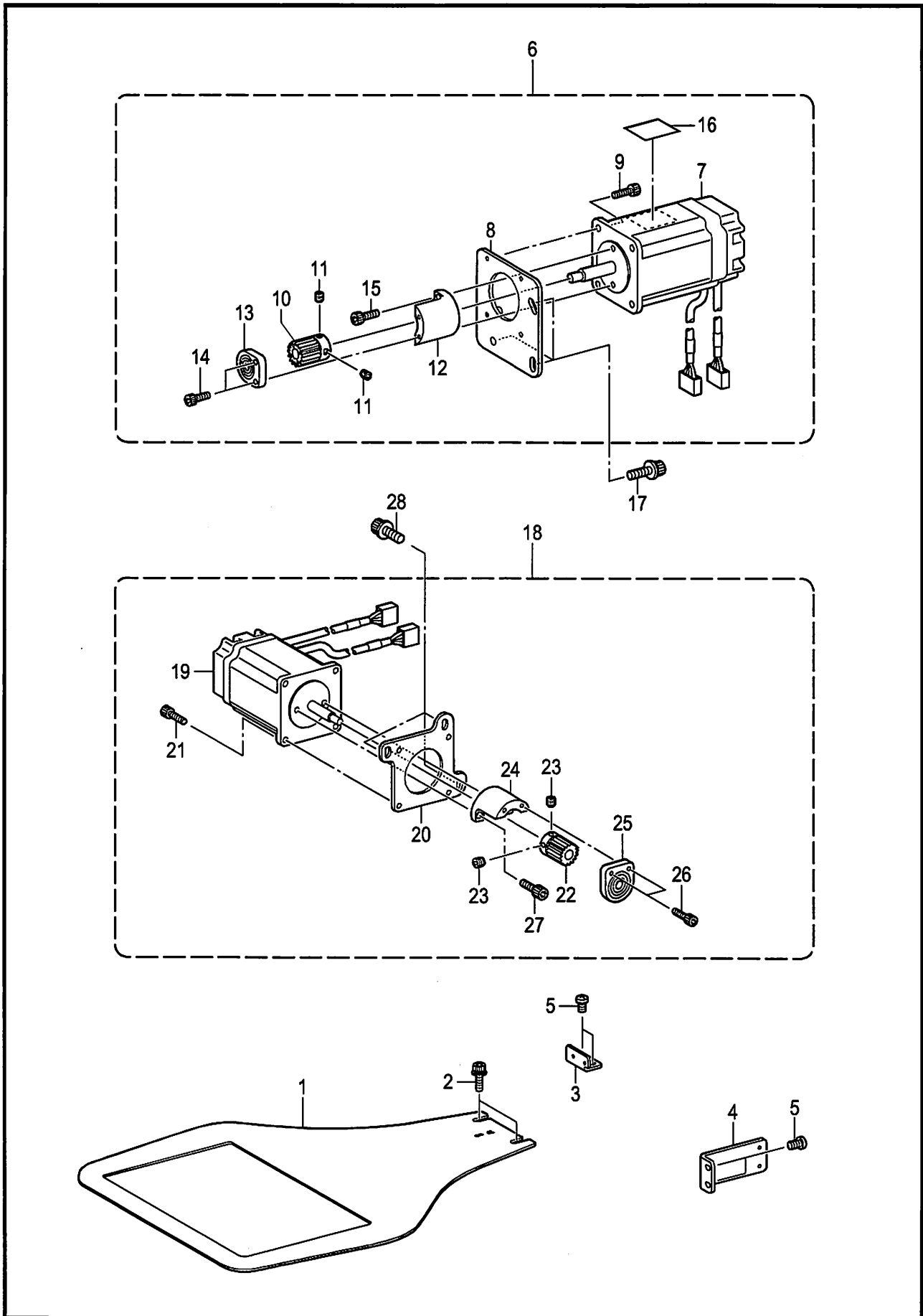

## C3. 送り関係 / Feed mechanism

REF.NO	CODE	QTY	品名	NAME OF PARTS	RM
1	SB4346001	1	オクリイタ311H	FEED PLATE 311H	
2	S55484001	2	アナボルトザクミ5X10	BOLT SOCKET (S/P WASHER)M5X10	
3	SB4343001	1	Xセンサトリツケイタ	X SENSOR PLATE	
4	SB4342001	1	Yセンサトリツケイタ	Y SENSOR PLATE	
5	062400616	4	ナベコ4X6	SCREW PAN M4X6	
6	SB4458001	1	Xオクリモータオクミ	X-FEED MOTOR L ASSY	
7	SB4275001	1	パルスモータXクミ	PULSE MOTOR ASSY X	
8	SB4334001	1	Xモータトリツケイタ	X MOTOR SETTING PLATE	
9	018401036	4	アナボルト4X10	BOLT SOCKET M4X10	
10	SA3707101	1	クドウギヤ16	GEAR 16	
11	012060536	2	アナヒラ6X5	SET SCREW, SOCKET (FT) M6X5	
12	SA6450101	1	ベアリングホルダベース	BEARING HOLDER BASE	
13	SA6451101	1	ベアリングホルダクミ	BEARING HOLDER ASSY	
14	018401036	2	アナボルト4X10	BOLT SOCKET M4X10	
15	018501036	2	アナボルト5X10	BOLT SOCKET M5X10	
16	SA4224001	1	マークチュウイ30X40	MARK ATTENTION 30X40	
17	S42446001	3	アナボルトザクミ6X14	BOLT SOCKET (S/P WASHER)M6X14	
18	SB4459001	1	Yオクリモータオクミ	Y-FEED MOTOR L ASSY	
19	SB4276001	1	パルスモータYクミ	PULSE MOTOR ASSY Y	
20	SB4372001	1	Yモータトリツケイタ	Y MOTOR SETTING PLATE	
21	018400836	4	アナボルト4X8	BOLT SOCKET M4X8	
22	SA4197101	1	オクリギア	FEED GEAR	
23	012060536	2	アナヒラ6X5	SET SCREW, SOCKET (FT) M6X5	
24	SA6450101	1	ベアリングホルダベース	BEARING HOLDER BASE	
25	SA6451101	1	ベアリングホルダクミ	BEARING HOLDER ASSY	
26	018401036	2	アナボルト4X10	BOLT SOCKET M4X10	
27	018501036	2	アナボルト5X10	BOLT SOCKET M5X10	
28	S55485001	3	アナボルトザクミ5X12	BOLT SOCKET (S/P WASHER)M5X12	

BAS-311H-202

C4. 送り関係 (-0□S) / Feed mechanism (-0□S)

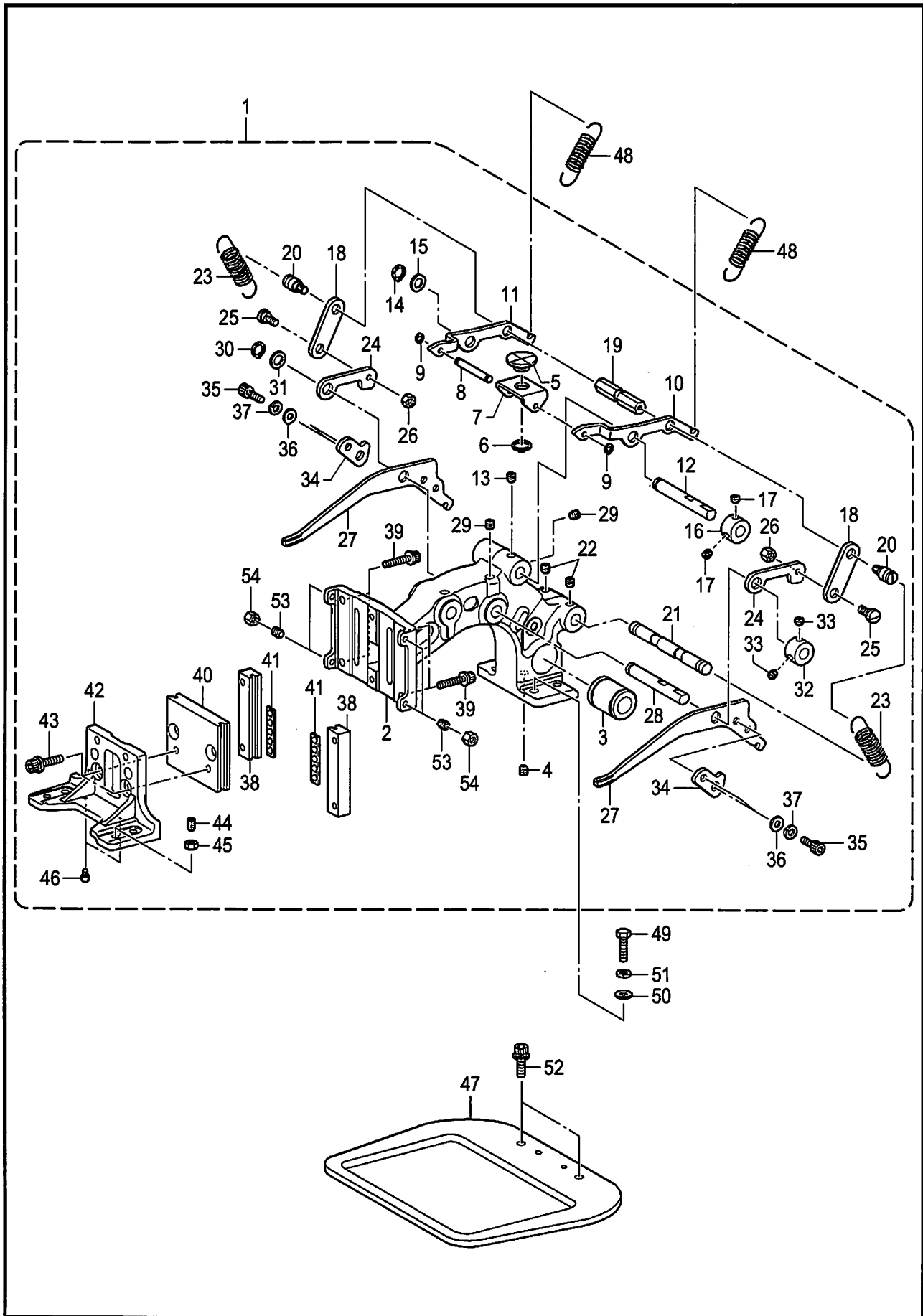

BAS-311H-202



C4. 送り関係 (-0[S]) / Feed mechanism (-0[S])

REF.NO	CODE	Q'TY	品名	NAME OF PARTS	RM
1	SB4433001	1	オサエウデ311Hクミ	WORK CLAMP ASSY 311H	
2	SB4404001	1	オサエウデ	WORK CLAMP ARM	
3	S35183000	1	リニアブツシュ12	LINEAR BUSH, 12	
4	012060636	1	アナヒラ6X6	SET SCREW SOCKET (FT) M6X6	
5	SA4687101	1	スライダ-	SLIDER	
6	048100142	1	トメワジクヨウC10	RETAINING RING EXTERNAL C10	
7	SA4688001	1	スライダ-ササエ	SUPPORT SLIDER	
8	SA4689001	1	スライダ-ササエジク	SUPPORT SHAFT SLIDER	
9	048040142	2	トメワジクヨウC4	RETAINING RING EXTERNAL C4	
10	SB4368001	1	オサエアゲレバ-R	WORK CLAMP LIFTER LEVER R	
11	SB4367001	1	オサエアゲレバ-L	WORK CLAMP LIFTER LEVER L	
12	SA4692001	1	オサエウデレバ-ジク	WORK CLAMP LIFTER SHAFT	
13	012060636	1	アナヒラ6X6	SET SCREW SOCKET (FT) M6X6	
14	048080142	1	トメワジクヨウC8	RETAINING RING EXTERNAL C8	
15	110367001	1	ザガネ	WASHER, PLAIN SPECIAL 8	
16	SA3231001	1	セットカラ-B	SET SCREW COLLAR,B	
17	012060536	2	アナヒラ6X5	SET SCREW, SOCKET (FT) M6X5	
18	SB4414001	2	レンカン	CONNECTING ROD	
19	SA4693001	1	バネカケジクA	SPRING HOLDER SHAFT A	
20	SB4375001	2	バネカケ	SPRING HOLDER	
21	SB4374001	1	バネカケジク	SPRING HOLDER SHAFT	
22	012060636	2	アナヒラ6X6	SET SCREW SOCKET (FT) M6X6	
23	SB4376001	2	モドシバネ	SPRING	
24	SB4421001	2	レンケツリンク	CONNECTING LINK	
25	SB4422001	2	ダンネジM4	SHOULDER SCREW M4	
26	021400216	2	2シュナット4	NUT 2 M4	
27	SB4377001	2	オサエウデレバ-	WORK CLAMP LIFTER	
28	SA4692001	1	オサエウデレバ-ジク	WORK CLAMP LIFTER SHAFT	
29	012060636	1	アナヒラ6X6	SET SCREW SOCKET (FT) M6X6	
30	048080142	1	トメワジクヨウC8	RETAINING RING EXTERNAL C8	
31	110367001	1	ザガネ	WASHER, PLAIN SPECIAL 8	
32	SA3231001	1	セットカラ-B	SET SCREW COLLAR,B	
33	012060536	2	アナヒラ6X5	SET SCREW, SOCKET (FT) M6X5	
34	SB4420001	2	ストッパー	STOPPER	
35	018500836	4	アナボルト5X8	BOLT SOCKET M5X8	
36	SB3849001	4	ヒラザガネチュウ5	WASHER_PLAIN_M_5	
37	028050246	4	バネザガネ2-5	WASHER SPRING 2-5	
38	SA4864001	2	オサエアシアンナイBクミ	WORK CLAMP GUIDE B ASSY	
39	S55482001	4	アナボルトザクミ4X14	BOLT SOCKET (S/P WASHER)M4X14	
40	SB2131001	1	オサエアシスライダ300G	WORK CLAMP SLIDER 300G	
41	SA4706101	2	オサエアシリテーナクミ	WORK CLAMP RETAINER ASSY	
42	SB4453001	1	オサエアシクミ	WORK CLAMP ASSY	
43	S55485001	2	アナボルトザクミ5X12	BOLT SOCKET (S/P WASHER)M5X12	
44	012501031	2	アナヒラ5X10	SET SCREW SOCKET (FT) M5X10	
45	021500216	2	2シュナット5	NUT 2 M5	
46	SA4709001	2	イチギメダンネジ	SHOULDER SCREW	
47	SB4457001	1	オサエイタ311Hクミ	WORK CLAMP 311H ASSY	
48	SB4373001	2	オサエバネ	WORK CLAMP SPRING	
49	017501616	4	ボルト5X16	BOLT M5X16	
50	SB3849001	4	ヒラザガネチュウ5	WASHER_PLAIN_M_5	
51	028050246	4	バネザガネ2-5	WASHER SPRING 2-5	
52	S55485001	2	アナボルトザクミ5X10	BOLT SOCKET (S/P WASHER)M5X10	
53	SB4525001	4	アナヒラ4X10	SET SCREW SOCKET (FT) M4X10	
54	021400106	4	1シュナット4	NUT 1 M4	

BAS-311H-202

C5. 送り関係 (-0□A) / Feed mechanism (-0□A)

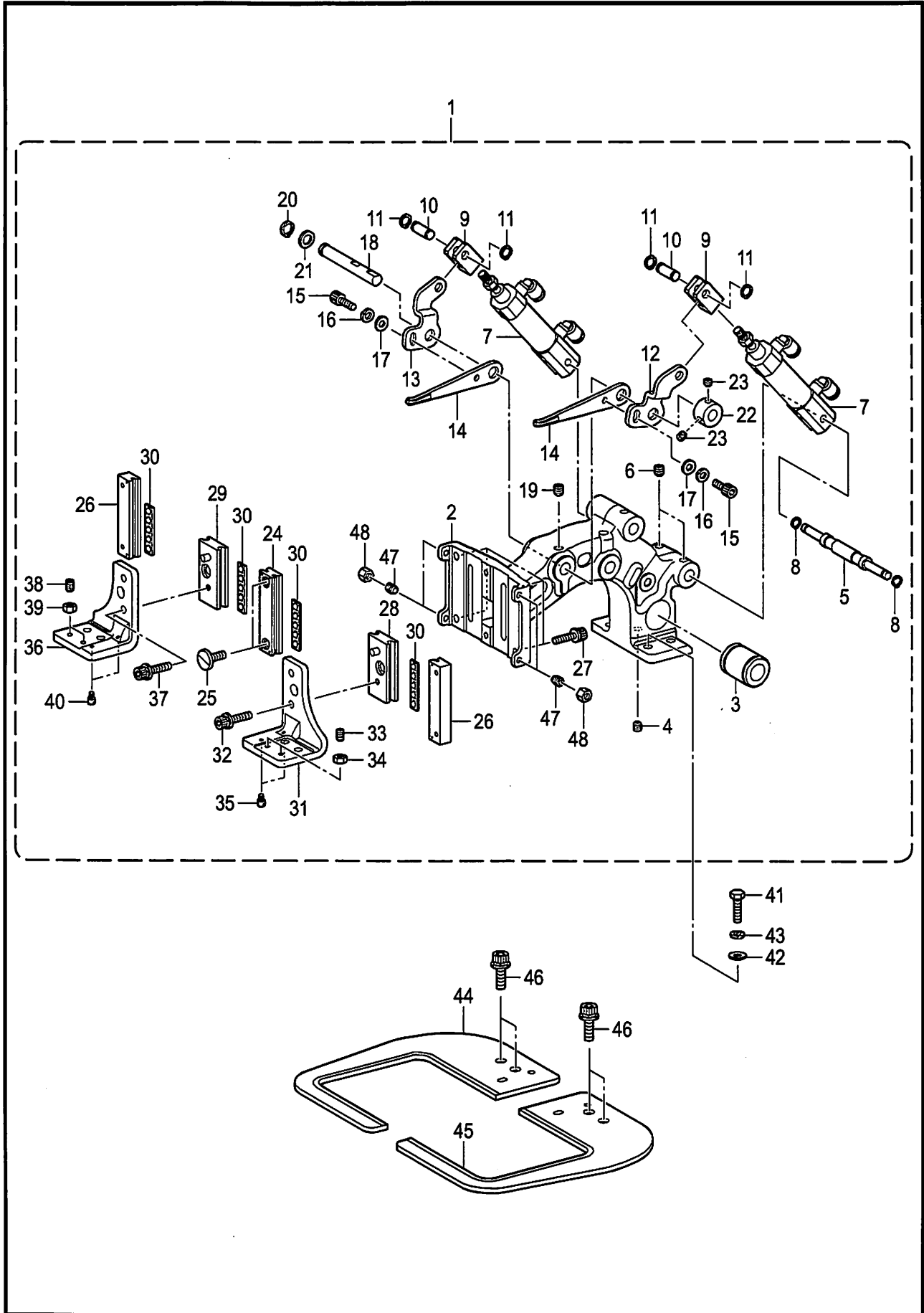

BAS-311H-202

C5. 送り関係 (-0□A) / Feed mechanism (-0□A)

REF.NO	CODE	Q'TY	品名	NAME OF PARTS	RM
1	SB4454001	1	オサエウデ311Hエアークミ	WORK CLAMP ASSY 311H AIR	
2	SB4404001	1	オサエウデ	WORK CLAMP ARM	
3	S35183000	1	リニアブツシュ12	LINEAR BUSH, 12	
4	012060636	1	アナヒラ6X6	SET SCREW SOCKET (FT) M6X6	
5	SA4717001	1	シリンダー-ジク	CYLINDER SHAFT	
6	012060636	2	アナヒラ6X6	SET SCREW SOCKET (FT) M6X6	
7	SA4719001	2	エアシリンダRクミ	AIR CYLINDER ASSY	
8	048050142	2	トメワジクヨウC5	RETAINING RING EXTERNAL C5	
9	SA4720001	2	シリンダー-ツギテ	CYLINDER JOINT	
10	SA4721001	2	シリンダー-ツギテジク	CYLINDER JOINT SHAFT	
11	048060142	4	トメワジクヨウC6	RETAINING RING EXTERNAL C6	
12	SB4371001	1	オサエウデレバー-R エア-	WORK CLAMP LIFTER LEVER R AIR	
13	SB4370001	1	オサエウデレバー-L エア-	WORK CLAMP LIFTER LEVER L AIR	
14	SB4369001	2	オサエウデレバー エア-	WORK CLAMP LIFTER LEVER AIR	
15	018400836	2	アナボルト4X8	BOLT SOCKET M4X8	
16	028040246	2	バネザガネ2-4	WASHER SPRING 2-4	
17	100645004	2	ザガネ	WASHER	
18	SA4692001	1	オサエウデレバー-ジク	WORK CLAMP LIFTER SHAFT	
19	012060636	1	アナヒラ6X6	SET SCREW SOCKET (FT) M6X6	
20	048080142	1	トメワジクヨウC8	RETAINING RING EXTERNAL C8	
21	110367001	1	ザガネ	WASHER, PLAIN SPECIAL 8	
22	SA3231001	1	セットカラ-B	SET SCREW COLLAR,B	
23	012060536	2	アナヒラ6X5	SET SCREW, SOCKET (FT) M6X5	
24	SA4863001	1	オサエアシアンナイAクミ	WORK CLAMP GUIDE A ASSY	
25	S23849101	2	シメネジ4X16	SCREW M4X16	
26	SA4864001	2	オサエアシアンナイBクミ	WORK CLAMP GUIDE B ASSY	
27	S55482001	4	アナボルトザクミ4X14	BOLT SOCKET (S/P WASHER)M4X14	
28	SA4712001	1	オサエアシスライダRクミ	WORK CLAMP SLIDER ASSY R	
29	SA4714001	1	オサエアシスライダLクミ	WORK CLAMP SLIDER ASSY L	
30	SA4706101	4	オサエアシリテ-ナクミ	WORK CLAMP RETAINER ASSY	
31	SB4455001	1	オサエアシRクミ	WORK CLAMP ASSY R	
32	S55485001	1	アナボルトザクミ5X12	BOLT SOCKET (S/P WASHER)M5X12	
33	012501031	2	アナヒラ5X10	SET SCREW SOCKET (FT) M5X10	
34	021500216	2	2シュナット5	NUT 2 M5	
35	SA4709001	2	イチギメダンネジ	SHOULDER SCREW	
36	SB4456001	1	オサエアシLクミ	WORK CLAMP ASSY L	
37	S55485001	1	アナボルトザクミ5X12	BOLT SOCKET (S/P WASHER)M5X12	
38	012501031	2	アナヒラ5X10	SET SCREW SOCKET (FT) M5X10	
39	021500216	2	2シュナット5	NUT 2 M5	
40	SA4709001	2	イチギメダンネジ	SHOULDER SCREW	
41	017501616	4	ボルト5X16	BOLT M5X16	
42	SB3849001	4	ヒラザガネチュウ5	WASHER_PLAIN_M_5	
43	028050246	4	バネザガネ2-5	WASHER SPRING 2-5	
44	SB4460001	1	オサエイタ311Hクミ L	WORK CLAMP 311H L ASSY	
45	SB4461001	1	オサエイタ311Hクミ R	WORK CLAMP 311H R ASSY	
46	S55485001	4	アナボルトザクミ5X10	BOLT SOCKET (S/P WASHER)M5X10	
47	SB4525001	4	アナヒラ4X10	SET SCREW SOCKET (FT) M4X10	
48	021400106	4	1シュナット4	NUT 1 M4	

BAS-311H-202

C6. 送り関係 (オプション部品) / Feed mechanism (Option parts)

< 送り板: 上締めタイプ  
/ Feed plate: For top-tightening type >

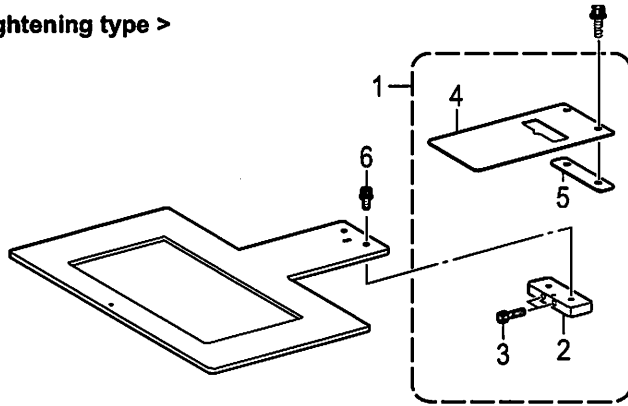

< 送り板: 下締めタイプ  
/ Feed plate: For bottom-tightening type >

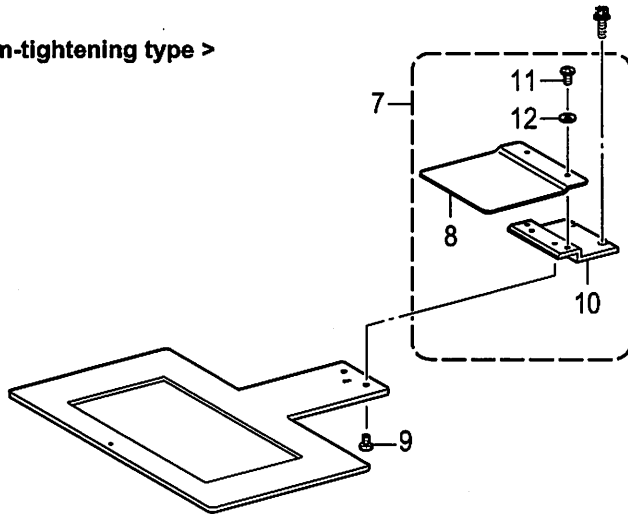

< 一体タイプ / For single type >

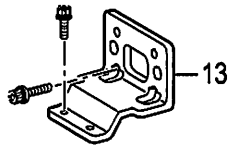

< 左右分離タイプ / For separate type >

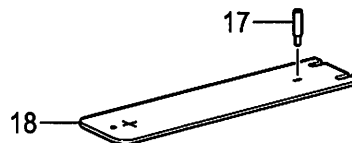
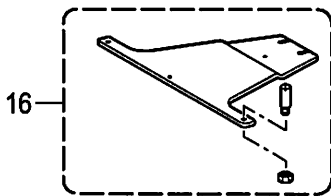
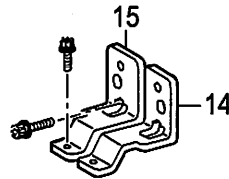

C6. 送り関係 (オプション部品) / Feed mechanism (Option parts)

REF.NO	CODE	Q'TY	品名	NAME OF PARTS	RM
			<送り板:上締めタイプ>	<Feed plate: For top-tightening type>	
1	SA7140001	1	311オクリイタヘンカンAクミ	311 FEED PLATE CHANGE A SET	
2	SA5291101	1	ヘンカンブロック	CHANGE PLATE	
3	018301436	2	アナボルト3X14	BOLT SOCKET M3X14	
4	SA5829001	1	オクリイタカバー-311-2	FEED PLATE COVER 311-2	
5	SA7139001	1	オクリイタカバー-311-3	FEED PLATE COVER 311-3	
6	S55479001	2	アナボルトザクミ4X8	BOLT SOCKET (S/P WASHER) M4X8	
			<送り板:下締めタイプ>	<Feed plate: For bottom-tightening type>	
7	SA7141001	1	311オクリイタヘンカンBクミ	311 FEED PLATE CHANGE B SET	
8	SA6604001	1	オクリイタカバー-311-1	FEED PLATE COVER 311-1	
9	S23418001	2	シメネジ4X5	SCREW M4X5	
10	SA6603001	1	オクリイタスペーサ	FEED PLATE SPACER	
11	S23418001	2	シメネジ4X5	SCREW M4X5	
12	025040236	2	ヒラザガネチューウ4	WASHER PLAIN M 4	
			<一体タイプ>	<For single type>	
13	SA6595001	1	オサエアシ311Fタイプ	WORK CLAMP 311F TYPE	
			<左右分離タイプ>	<For separate type>	
14	SA6599001	1	オサエアシ311FRタイプ	WORK CLAMP 311F R TYPE	
15	SA6600001	1	オサエアシ311FLタイプ	WORK CLAMP 311F L TYPE	
			<カセットオサエ>	<Cassette clamp>	
16	SA7385001	1	カセットシジイタ311Gクミ	CASSETTE BOARD 311G ASSY	
17	SA5415001	2	ゲンテンキジュンピン	ORIGIN STANDARD PIN	
18	SB4713001	1	ゲンテンキジュンイタ	ORIGIN STANDARD PLATE	

BAS-311H-202

D1. 押え上げ関係 / Work clamp lifter mechanism

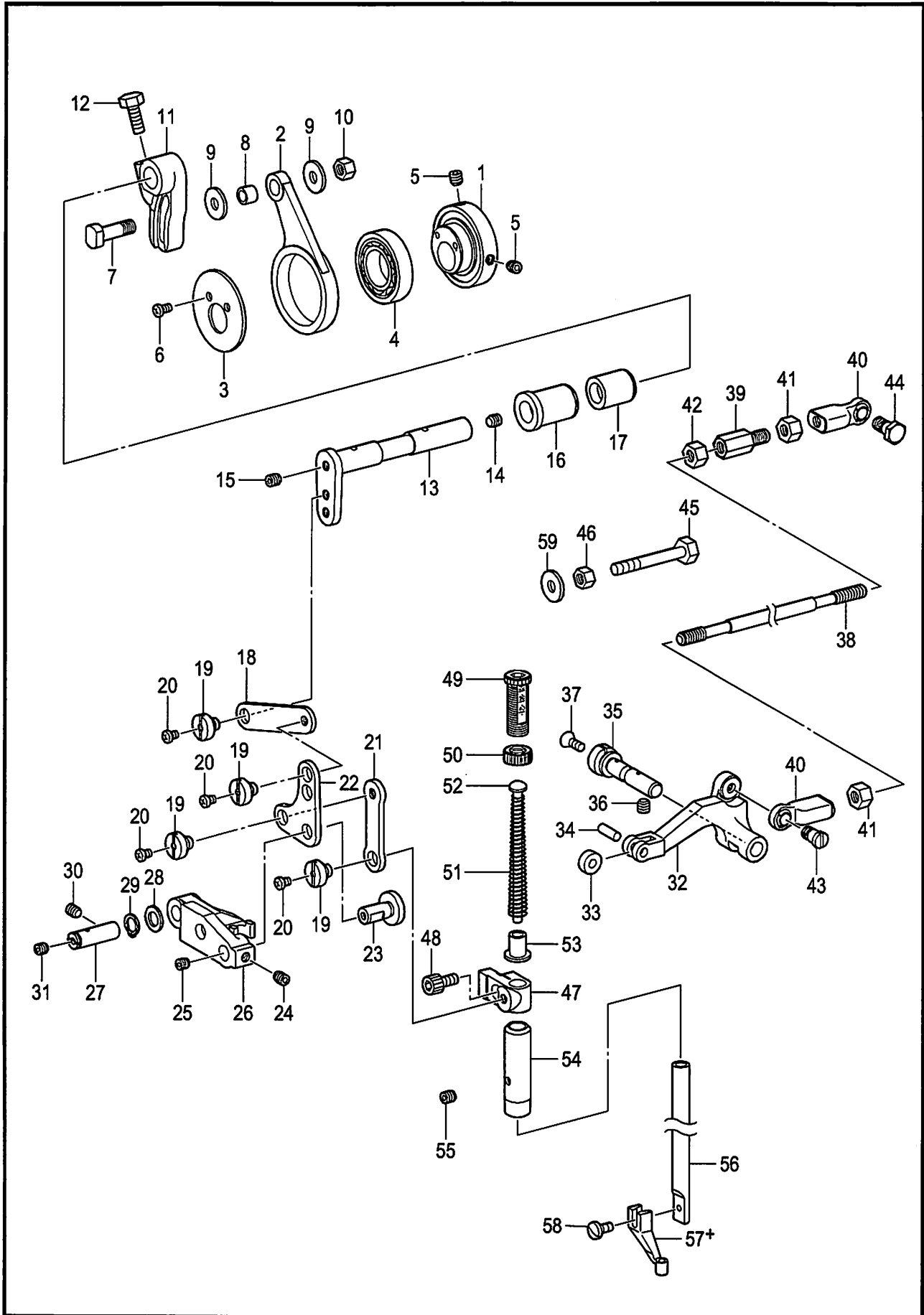

BAS-311H-204

## D1. 押え上げ関係 / Work clamp lifter mechanism

REF.NO	CODE	Q'TY	品名	NAME OF PARTS	RM
1	SA4759001	1	カンケツオサエカム	STEPPING CLAMP CAM	
2	SA4760001	1	カンケツオサエレンカン	STEPPING CLAMP CON.ROD	
3	SA4763001	1	カンケツオサエカム ザガネ	WASHER STEPPING CLAMP CAM	
4	SA7704001	1	タマジクウケ6805VV	BALL BEARING 6805VV	
5	S23651001	2	アナヒラ6X6ホソメ	SET SCREW, SOCKET (FT) M6X6	
6	062400616	2	ナベコ4X6	SCREW PAN M4X6	
7	SA4761001	1	カンケツオサエウデコロジク	ROLLER SHAFT STEPPING CLAMP	
8	SA4762001	1	カンケツオサエウデコロ	ROLLER STEPPING CLAMP	
9	SA4302001	2	ザガネ	WASHER	
10	021060106	1	1シュナット6	NUT 1 M6	
11	SA4764001	1	カンケツオサエウデR	STEPPING CLAMP ARM R	
12	017061213	1	ボルト6X12	BOLT M6X12	
13	SA4765001	1	カンケツオサエウデF	STEPPING CLAMP ARM F	
14	012060636	1	アナヒラ6X6	SET SCREW SOCKET (FT) M6X6	
15	S23651001	1	アナヒラ6X6ホソメ	SET SCREW, SOCKET (FT) M6X6	
16	SA4766001	1	カンケツオサエウデメタルF	BUSH STEPPING CLAMP F	
17	SA4767001	1	カンケツオサエウデメタルR	BUSH STEPPING CLAMP R	
18	SA4768001	1	カンケツレンカンA	STEPPING CLAMP LINK A	
19	SA4769101	4	ダンネジ6	SHOULDER SCREW 6	
20	062300416	4	ナベコ3X4	SCREW, PAN M3X4	
21	SA4770001	1	カンケツレンカンB	STEPPING CLAMP LINK B	
22	SA4772001	1	カンケツリンク	STEPPING CLAMP LINK	
23	SA4773001	1	カンケツリンクジク	SHAFT STEPPING CLAMP LINK	
24	012060636	1	アナヒラ6X6	SET SCREW SOCKET (FT) M6X6	
25	012400436	1	アナヒラ4X4	SET SCREW SOCKET (FT) M4X4	
26	SA4777001	1	カンケツアゲリンク	STEPPING CLAMP LIFTER LINK	
27	SA4771001	1	カンケツアゲリンクジク	SHAFT STEPPING CLAMP LIFT LINK	
28	SA2161001	1	ザガネ	WASHER	
29	048080142	1	トメワジクヨウC8	RETAINING RING EXTERNAL C8	
30	012060636	1	アナヒラ6X6	SET SCREW SOCKET (FT) M6X6	
31	012400436	1	アナヒラ4X4	SET SCREW SOCKET (FT) M4X4	
32	SA4779101	1	カンケツアゲレバ-	STEPPING CLAMP LIFTER	
33	SA4781001	1	カンケツアゲレバ-コロ	ROLLER STEPPING CLAMP LIFTER	
34	141362001	1	エントウコロ	ROLLER	
35	SA4780001	1	カンケツアゲレバ-ジク	SHAFT STEPPING CLAMP LIFTER	
36	012060636	1	アナヒラ6X6	SET SCREW SOCKET (FT) M6X6	
37	S25310101	1	サラネジ4	SCREW, FLAT M4	
38	SA4775101	1	カンケツアゲロッド	STEPPING CLAMP LIFTER ROD	
39	SA4853001	1	カンケツアゲロッドツギテ	JOINT STEPPING CLAMP LIFTER	
40	SA8684001	2	タマツギテクミ	ROUND JOINT ASSY	
41	021060306	2	3シュナット6	NUT 3 M6	
42	SA3227001	1	ナット6ホソメ	NUT(FT),M6	
43	SA8689001	1	シメネジ6X12	SCREW M6X12	
44	017061612	1	ボルト6X16	BOLT M6X16	
45	017065002	1	ボルト6X50	BOLT M6X50	
46	021060106	1	1シュナット6	NUT 1 M6	
47	SA4778001	1	オサエボウダキ	PRESSER BAR CLAMP	
48	018400836	1	アナボルト4X8	BOLT SOCKET M4X8	
49	SA1174002	1	オサエチヨウセツネジM14	PRESSER ADJUSTING SCREW, M14	
50	SA1175002	1	チヨウセツネジナットM14	ADJUST SCREW NUT	
51	SA5300001	1	オサエバネ	PRESSER BAR SPRING	
52	S10112101	1	オサエバネアンナイ	PRESSER BAR SPRING GUIDE	
53	SA5301001	1	オサエバネカラ-	COLLAR PRESSER BAR SPRING	
54	SA2195001	1	オサエボウメタル	PRESSER BAR BUSH	
55	012060536	1	アナヒラ6X5	SET SCREW SOCKET (FT) M6X5	
56	111466121	1	オサエボウ	PRESSER BAR	
57+	* P.68-69	1	オサエアシ	WORK CLAMP	
58	S13399001	1	シメネジ3.57X12	SCREW, SM3.57X12	
59	151439102	1	ザガネ	WASHER	

BAS-311H-204

D2. 押え上げ関係 (-0□S) / Work clamp lifter mechanism (-0□S)

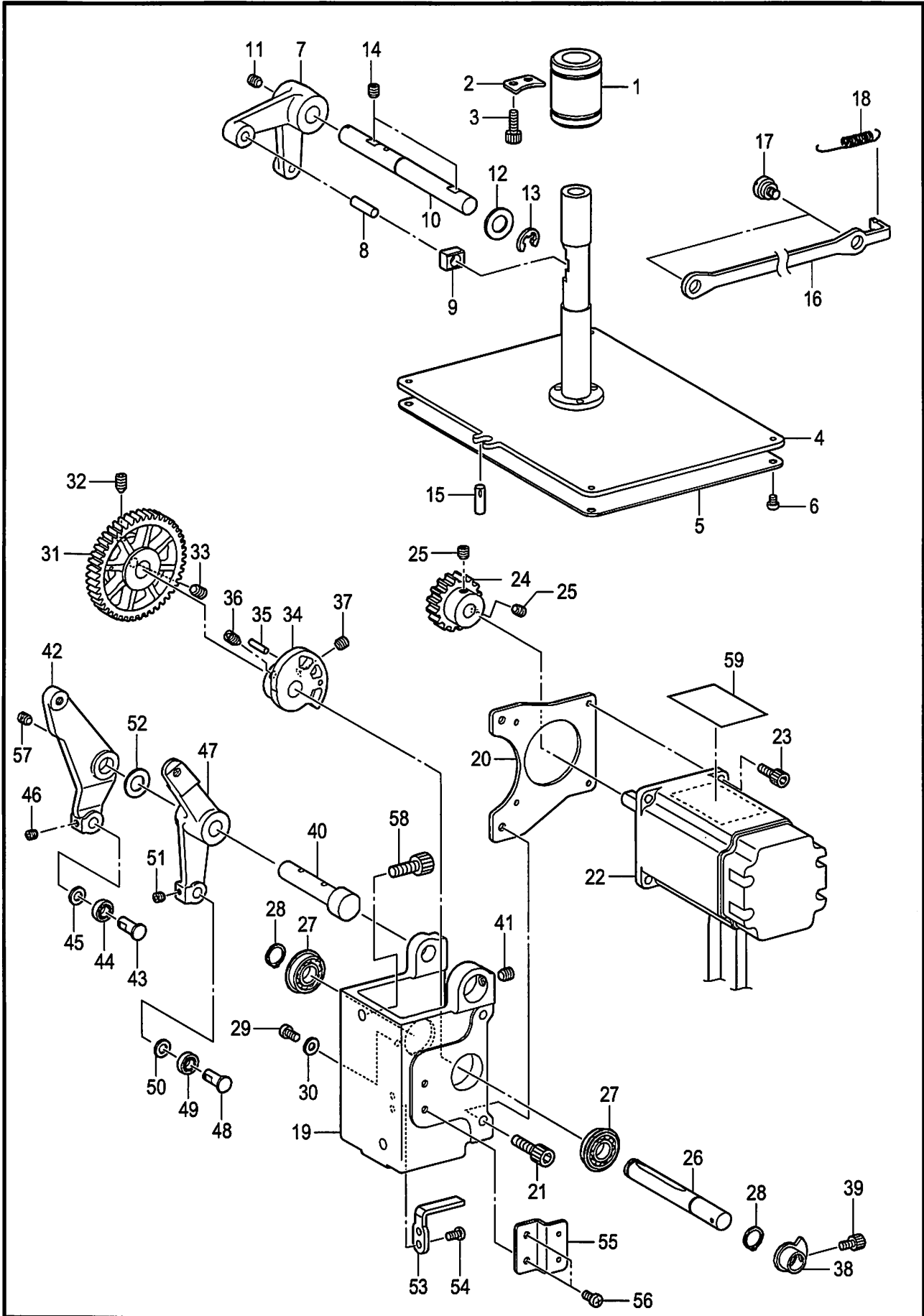

BAS-311H-204



D2. 押え上げ関係 (-0[S]) / Work clamp lifter mechanism (-0[S])

REF.NO	CODE	Q'TY	品名	NAME OF PARTS	RM
1	SA5593001	1	ボールブツシュ	LINEAR BUSH 16	
2	SB4381001	1	リニアブシュトメイタ	LINEAR BUSH SETTING PLATE	
3	018400836	2	アナボルト4X8	BOLT SOCKET M4X8	
4	SB4424001	1	オサエアゲイタクミ	WORK CLAMP LIFTER PLATE ASSY	
5	SB4423001	1	シートE 150X100	SEAT E 150X100	
6	062400416	4	ナベコ4X4	SCREW, PAN M4X4	
7	SA4736001	1	オサエアゲレバー	WORK CLAMP LIFTER LEVER	
8	152744001	1	ヨコオクリカクコマピン	PIN	
9	102630021	1	ハリボウアンナイカクコマ	NEEDLE BAR GUIDE SLIDE BLOCK	
10	SA4737001	1	オサエアゲレバー-ジクB	WORK CLAMP LEVER SHAFT B	
11	012060636	1	アナヒラ6X6	SET SCREW SOCKET (FT) M6X6	
12	S20356001	1	ヒラザガネ10	WASHER, PLAIN 10	
13	048080342	1	トメワE8	RETAINING RING E8	
14	012060636	2	アナヒラ6X6	SET SCREW SOCKET (FT) M6X6	
15	118208001	1	ミゾツキピン	DOWEL PIN	
16	SA4738001	1	オサエアゲリンク	WORK CLAMP LIFTER LINK	
17	SB0705101	2	オサエアゲリンクダンネジ	LINK SHOULDER SCREW	
18	SA4739001	1	オサエアゲバネ	WORK CLAMP SPRING	
19	SA4741301	1	モーターブラケット	MOTOR BRACKET	
20	SB4382001	1	オサエアゲモータイタ	WORK CLAMP MOTOR PLATE	
21	018501036	2	アナボルト5X10	BOLT SOCKET M5X10	
22	SB4277001	1	パルスモータPクミ	PULSE MOTOR ASSY P	
23	018401036	4	アナボルト4X10	BOLT SOCKET M4X10	
24	SA4743001	1	オサエアゲドウギヤ	WORK CLAMP DRIVING GEAR	
25	012060636	2	アナヒラ6X6	SET SCREW SOCKET (FT) M6X6	
26	SA4744001	1	オサエアゲシテンジク	WORK CLAMP FULCRUM SHAFT	
27	SA4647001	2	タマジクウケ6900ZZNR	BALL BEARING 6900ZZNR	
28	048100142	2	トメワジクヨウC10	RETAINING RING EXTERNAL C10	
29	062400616	1	ナベコ4X6	SCREW PAN M4X6	
30	SB3848001	1	ヒラザガネチュウ4	WASHER PLAIN M 4	
31	SA4745001	1	オサエアゲカムギヤ	WORK CLAMP CAM GEAR	
32	016061031	1	アナトガリ6X10	SET SCREW SOCKET (CN) M6X10	
33	012060636	1	アナヒラ6X6	SET SCREW SOCKET (FT) M6X6	
34	SA4746001	1	オサエアゲカム	WORK CLAMP CAM	
35	S35079000	1	ニードルローラ3X11.8	NEEDLE ROLLER, 3X11.8	
36	016061031	1	アナトガリ6X10	SET SCREW SOCKET (CN) M6X10	
37	012060636	1	アナヒラ6X6	SET SCREW SOCKET (FT) M6X6	
38	SA4747001	1	オサエゲンテンドグ	WORK CLAMP H-POSITION DOG	
39	018400636	1	アナボルト4X6	BOLT SOCKET M4X6	
40	SA4748101	1	オサエアゲレバー-ジク	WORK CLAMP LEVER SHAFT	
41	012060636	1	アナヒラ6X6	SET SCREW SOCKET (FT) M6X6	
42	SA6210001	1	カンケツクドウレバー	STEPPING W-CLAMP DRIVING LEVER	
43	SA3441101	1	オサエアゲコロジク	W-CLAMP LIFTER ROLLER SHAFT	
44	070696800	1	Rタマジクウケ696ZZ	BALL BEARING RADIAL 696ZZ	
45	109763022	1	ザガネ	WASHER	
46	012500536	1	アナヒラ5X5	SET SCREW SOCKET (FT) M5X5	
47	SA4750001	1	オサエアゲドウレバー	WORK CLAMP DRIVING SHAFT	
48	SA3441101	1	オサエアゲコロジク	W-CLAMP LIFTER ROLLER SHAFT	
49	070696800	1	Rタマジクウケ696ZZ	BALL BEARING RADIAL 696ZZ	
50	109763022	1	ザガネ	WASHER	
51	012500536	1	アナヒラ5X5	SET SCREW SOCKET (FT) M5X5	
52	S20356001	1	ヒラザガネ10	WASHER, PLAIN 10	
53	SA4752001	1	オサエアゲカムストッパ	WORK CLAMP CAM STOPPER	
54	062400616	2	ナベコ4X6	SCREW PAN M4X6	
55	SA4753001	1	オサエアゲセンサーイタ	WORK CLAMP SENSOR PLATE	
56	062400616	2	ナベコ4X6	SCREW PAN M4X6	
57	012060636	1	アナヒラ6X6	SET SCREW SOCKET (FT) M6X6	
58	018061236	2	アナボルト6X12	BOLT SOCKET M6X12	
59	SA4224001	1	マークチュウイ30X40	MARK ATTENTION 30X40	

BAS-311H-204

D3. 押え上げ関係 (-0□A) / Work clamp lifter mechanism (-0□A)

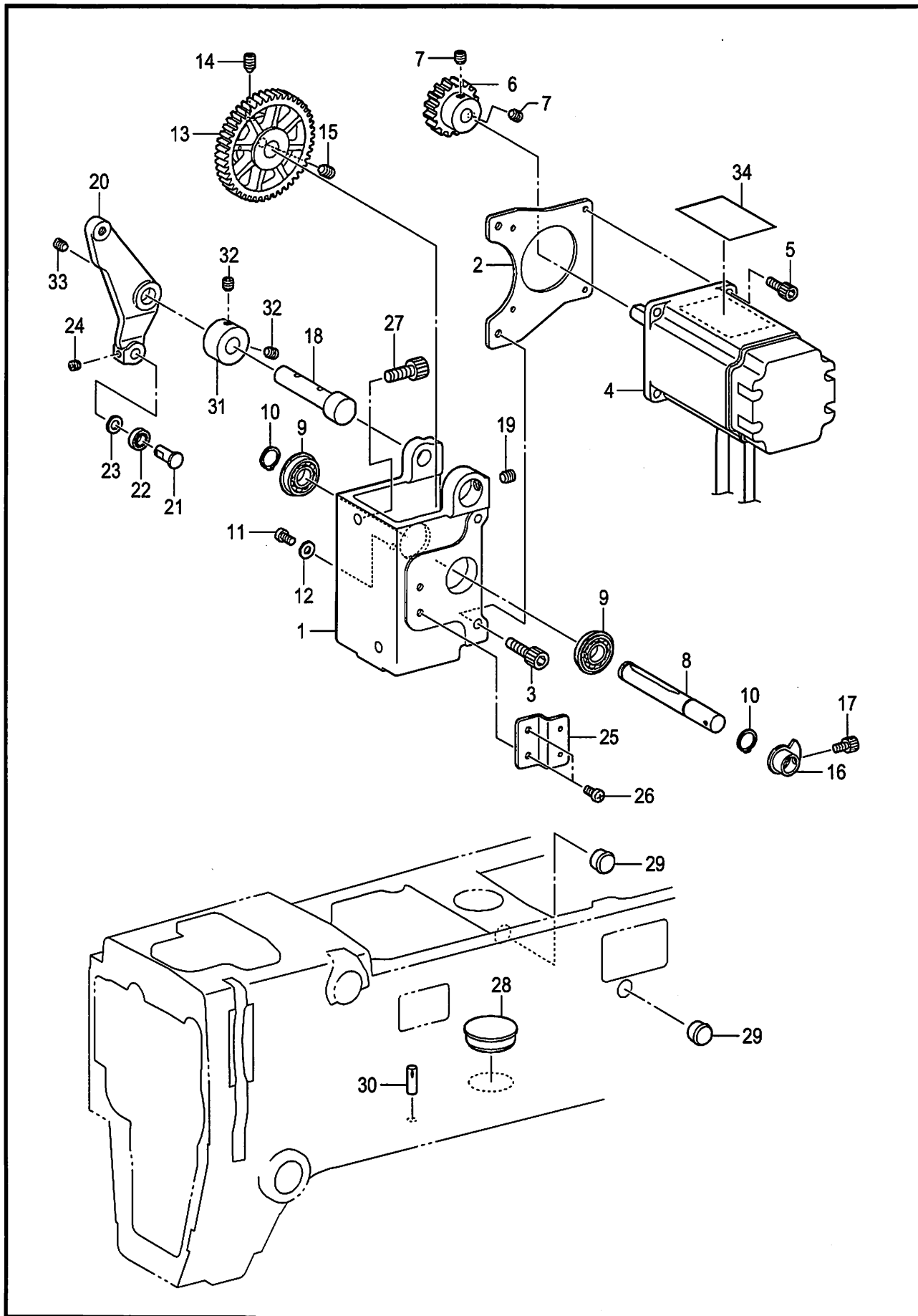

BAS-311H-204

D3. 押え上げ関係 (-0□A) / Work clamp lifter mechanism (-0□A)

REF.NO	CODE	Q'TY	品名	NAME OF PARTS	RM
1	SA4741301	1	モーターブラケット	MOTOR BRACKET	
2	SB4382001	1	オサエアゲモータイタ	WORK CLAMP MOTOR PLATE	
3	018501036	2	アナボルト5X10	BOLT SOCKET M5X10	
4	SB4277001	1	パルスモータPクミ	PULSE MOTOR ASSY P	
5	018401036	4	アナボルト4X10	BOLT SOCKET M4X10	
6	SA4743001	1	オサエアゲドウギヤ	WORK CLAMP DRIVING GEAR	
7	012060636	2	アナヒラ6X6	SET SCREW SOCKET (FT) M6X6	
8	SA4744001	1	オサエアゲシテンジク	WORK CLAMP FULCRUM SHAFT	
9	SA4647001	2	タマジクウケ6900ZZNR	BALL BEARING 6900ZZNR	
10	048100142	2	トメワジクヨウC10	RETAINING RING EXTERNAL C10	
11	062400616	1	ナベコ4X6	SCREW PAN M4X6	
12	SB3848001	1	ヒラザガネチュウ4	WASHER_PLAIN_M_4	
13	SA4745001	1	オサエアゲカムギヤ	WORK CLAMP CAM GEAR	
14	016061031	1	アナトガリ6X10	SET SCREW SOCKET (CN) M6X10	
15	012060636	1	アナヒラ6X6	SET SCREW SOCKET (FT) M6X6	
16	SA4747001	1	オサエゲンテンドグ	WORK CLAMP H-POSITION DOG	
17	018400636	1	アナボルト4X6	BOLT SOCKET M4X6	
18	SA4748101	1	オサエアゲレバ-ジク	WORK CLAMP LEVER SHAFT	
19	012060636	1	アナヒラ6X6	SET SCREW SOCKET (FT) M6X6	
20	SA6210001	1	カンケツクドウレバ-	STEPPING W-CLAMP DRIVING LEVER	
21	SA3441001	1	オサエアゲコロジク	W-CLAMP LIFTER ROLLER SHAFT	
22	070696800	1	Rタマジクウケ696ZZ	BALL BEARING RADIAL 696ZZ	
23	109763022	1	ザガネ	WASHER	
24	012500536	1	アナヒラ5X5	SET SCREW SOCKET (FT) M5X5	
25	SA4753001	1	オサエアゲセンサーイタ	WORK CLAMP SENSOR PLATE	
26	062400616	2	ナベコ4X6	SCREW PAN M4X6	
27	018061236	2	アナボルト6X12	BOLT SOCKET M6X12	
28	159163000	1	ゴムセン29	RUBBER CAP 29	
29	104821001	2	ゴムセン10.5	RUBBER CAP, 10.5	
30	118550001	1	ミゾツキピン	PIN DOWEL	
31	SA4757101	1	セットカラ-	SET SCREW COLLAR	
32	012060636	2	アナヒラ6X6	SET SCREW SOCKET (FT) M6X6	
33	012060636	1	アナヒラ6X6	SET SCREW SOCKET (FT) M6X6	
34	SA4224001	1	マークチュウイ30X40	MARK ATTENTION 30X40	

BAS-311H-204

E. 下軸関係 / Lower shaft mechanism

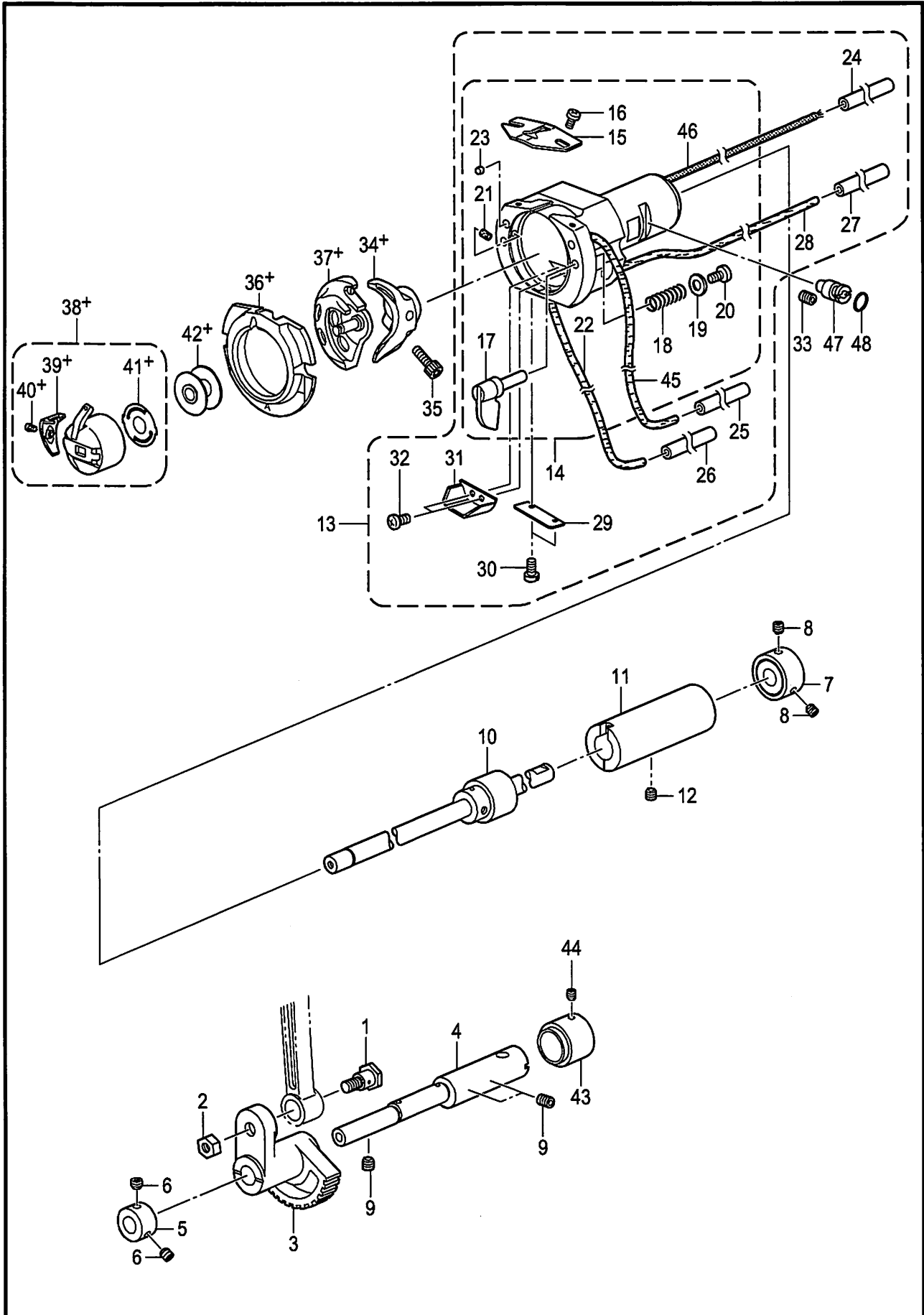

BAS-311H-305

E. 下軸関係 / Lower shaft mechanism

REF.NO	CODE	Q'TY	品名	NAME OF PARTS	RM
1	SA3226001	1	クランクロッドダンネジ	SHOULDER SCREW	
2	SA3227001	1	ナツト6ホソメ	NUT (FT), M6	
3	SA3228101	1	ヨウドウギヤ	ROCK GEAR	
4	SA4782001	1	ヨウドウギヤジク	ROCK GEAR SHAFT	
5	SA3231001	1	セツトカラ-B	SET SCREW COLLAR, B	
6	012060536	2	アナヒラ6X5	SET SCREW, SOCKET (FT) M6X5	
7	SA3233101	1	セツトカラ	SET SCREW COLLAR	
8	S23651001	2	アナヒラ6X6ホソメ	SET SCREW, SOCKET (FT) M6X6	
9	012060636	3	アナヒラ6X6	SET SCREW SOCKET (FT) M6X6	
10	SA4783101	1	シタジククミ	LOWER SHAFT ASSY	
11	SB4405001	1	シタジクメタル	LOWER SHAFT BUSH	
12	012060636	1	アナヒラ6X6	SET SCREW SOCKET (FT) M6X6	
13	SB4508101	1	オオカマタイHソウクミ	SHUTTLE RACE BASE SET H	
14	SB4509001	1	オオカマタイHクミ	SHUTTLE RACE BASE ASSY H	
15	S02429201	1	カマイトアンナイ	SHUTTLE RACE THREAD GUIDE	
16	SA4199001	2	シメネジ3X4	SCREW M3X4	
17	SA3241001	2	オオカマトリツケツメ	S-RACE BASE SETTING CLAW	
18	152684101	2	オオカマトリツケバネ	COMPRESSION SPRING	
19	402887001	2	ザガネ3.2	WASHER, 3.2	
20	062300616	2	ナベコ3X6	SCREW PAN M3X6	
21	SA9396001	2	フェルト	FELT	
22	S59886001	1	フェルト	FELT, L=360	
23	SA9397001	2	ゴムセン5.5	RUBBER CAP 5.5	
24	SA9793001	1	ビニルチューブ	VINYL TUBE L=160	
25	S50557000	1	ビニルチューブ	OIL TUBE	
26	SB3511001	1	ビニルチューブ	VINYL TUBE	
27	SB4392001	1	ビニルチューブ	OIL TUBE L=360	
28	SB4464101	1	フェルトクミ	FELT ASSY	
29	SA3242001	1	フェルトササエ	FELT HOLDER	
30	SA9191001	2	シメネジM3X5.5	SCREW M3X5.5	
31	SA3274101	1	フェルトオサエ	FELT HOLDER	
32	S47307001	2	シメネジ3X4	SCREW, M3X4	
33	012060636	1	アナヒラ6X6	SET SCREW SOCKET (FT) M6X6	
34+	* P.67	1	ドライバー	DRIVER	
35	018501232	1	アナボルト5X12	BOLT SOCKET M5X12	
36+	* P.67	1	オオカマ	SHUTTLE RACE BASE	
37+	* P.67	1	ナカカマ	SHUTTLE HOOK	
38+	* P.67	1	ボビンケースクミ	BOBBIN CASE ASSY	
39+	* P.67	1	ケースチヨウシバネ	TENSION SPRING	
40+	* P.67	1	ボビンケースバネネジ	BOBBIN CASE SPRING SCREW	
41+	* P.67	1	クウテンボウシバネ	ANTI-SPIN SPRING	
42+	* P.67	1	ボビン	BOBBIN	
43	SA3283101	1	セツトカラ-R	SET SCREW COLLAR, R	
44	012500536	1	アナヒラ5X5	SET SCREW SOCKET (FT) M5X5	
45	SA8707001	1	フェルト	FELT	
46	108802001	1	クミヒモ4X4	WICK, 4X4 L=250	
47	SA3238301	1	カマチヨウセツジク	ADJUSTING STUD	
48	081003670	1	OリングPW3	O RING PW3	

BAS-311H-305

F. 給油潤滑關係 / Lubrication

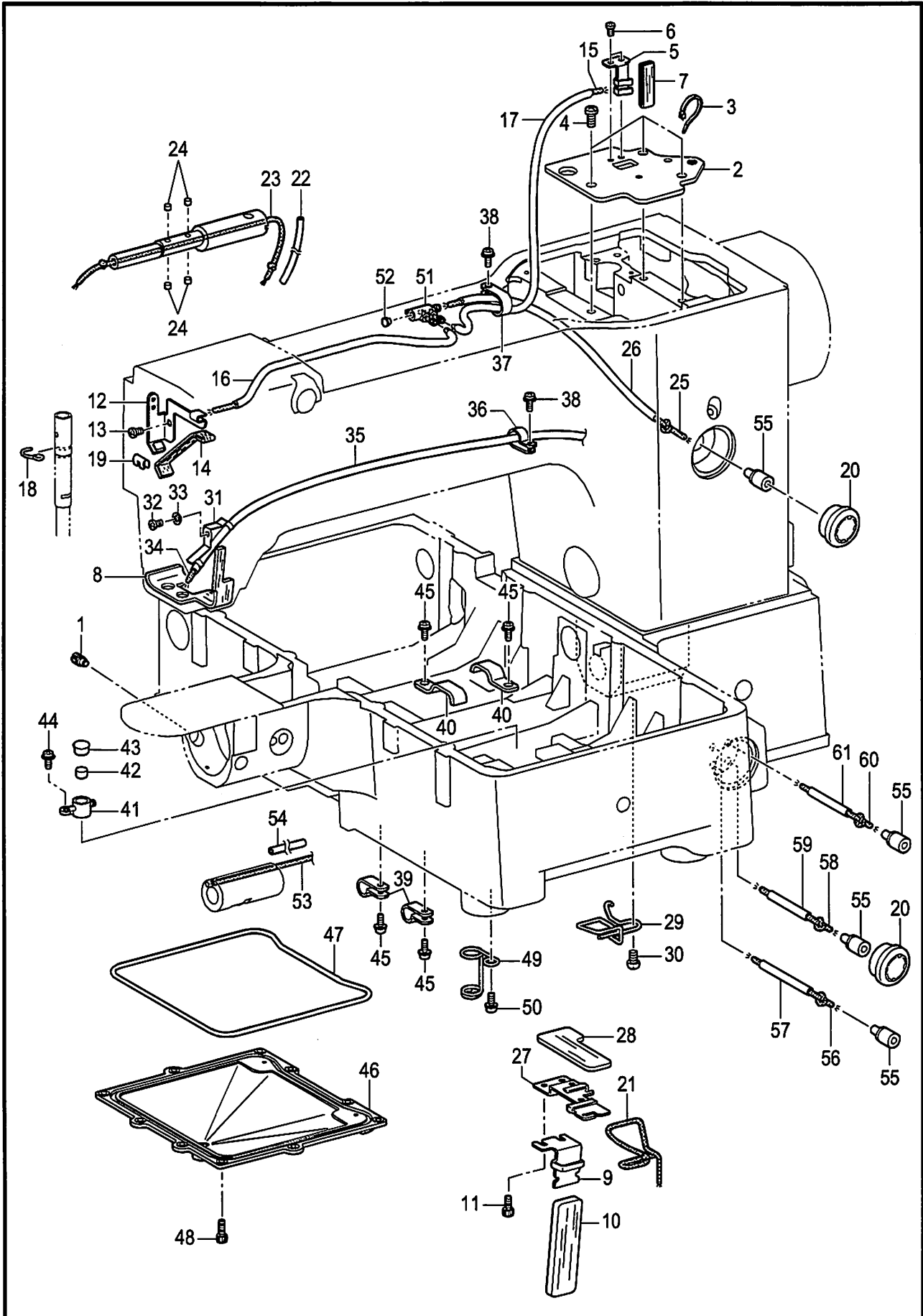

BAS-311H-350

F. 給油潤滑関係 / Lubrication

REF.NO	CODE	Q'TY	品名	NAME OF PARTS	RM
1	SA3244001	1	トメネジ	SET SCREW	
2	SA4785101	1	クランクカバー	CRANK COVER	
3	SB4155001	1	バンド	BAND	
4	062061016	3	ナベコ6X10	SCREW PAN M6X10	
5	SA4787001	1	クランクキユウユイタ	CRANK WICK PLATE	
6	062400616	2	ナベコ4X6	SCREW PAN M4X6	
7	SA5294001	1	ヒラクミヒモ	FLAT WICK L=90	
8	SA4786101	1	スィアゲフェルト	FELT	
9	SA3503201	1	シタジクキユウユササエ	LOWER SHAFT WICK SUPPORT	
10	SA3504201	1	シタジクギヤフェルト	LOWER SHAFT GEAR FELT	
11	018400636	2	アナボルト4X6	BOLT SOCKET M4X6	
12	SA4788001	1	テンビンキユウユササエ	WICK SUPPORT	
13	062400616	1	ナベコ4X6	SCREW PAN M4X6	
14	SA6593001	1	ヒラクミヒモ	FLAT WICK, L=180	
15	SA6580001	1	クミヒモ	WICK L=780	
16	S07459100	1	ビニルチューブ	OIL TUBE, L=240	
17	SA6576001	1	ビニルチューブ	OIL TUBE, L=210	
18	SA6087001	1	ハリボウヒモササエ	WICK SUPPORT	
19	104567101	1	クミヒモササエ	WICK SUPPORT	
20	S49992000	2	オイルポットマド	OIL GAUGE WINDOW	
21	SA4025001	1	クミヒモ4X4 L=180	WICK, 4X4 L=180	
22	SA2864001	1	ビニルチューブ	OIL TUBE L=193	
23	SB4524001	1	クミヒモ6X6	WICK 6X6 L=380	
24	S09043000	4	フェルト	FELT	
25	S49982000	1	クミヒモ4X4	WICK, 4X4 L=400	
26	S48189000	1	オイルチューブ	OIL TUBE, L=280	
27	SA3246001	1	ギヤキユウユササエ	GEAR WICK SUPPORT	
28	SA3280001	1	ギヤフェルト	GEAR FELT	
29	SA4789101	1	シタジクキユウユササエB	LOWER SHAFT WICK SUPPORT B	
30	062060816	1	ナベコ6X8	SCREW PAN M6X8	
31	145547021	1	チューブホルダ	TUBE HOLDER	
32	062400616	1	ナベコ4X6	SCREW PAN M4X6	
33	026040136	1	ヒラザガネコガタ	WASHER PLAIN S 4	
34	S49957000	1	クミヒモ4X4	WICK, 4X4 L=700	
35	SA4791101	1	ビニルチューブ	OIL TUBE L=620	
36	149547000	1	コードオサエ	CORD HOLDER, 4N	
37	525567000	1	コードホルダ#8	CORD HOLDER, #8	
38	0A5401006	2	+ナベザクミ4X10DB	SCREW PAN (S/P WASHER) M4X10	
39	525664000	2	コードホルダ#6	CORD HOLDER, #6	
40	SA1394101	2	コードオサエU3	CORD HOLDER U3	
41	SB4468001	3	ターミナル	TERMINAL	
42	S38266000	3	カマジクフェルト	ROTARY HOOK SHAFT FELT	
43	SA2929001	3	ゴムセン12.5	RUBBER CAP, 12.5	
44	0A5401006	3	+ナベザクミ4X10DB	SCREW PAN (S/P WASHER) M4X10	
45	0A5401006	4	+ナベザクミ4X10DB	SCREW PAN (S/P WASHER) M4X10	
46	SB4387001	1	オイルカバー	OIL COVER	
47	SB4388001	1	オイルカバーパッキン	OIL COVER PACKING	
48	018401036	10	アナボルト4X10	BOLT SOCKET M4X10	
49	S50359001	1	チューブササエD	TUBE SUPPORT, D	
50	0A5401006	1	+ナベザクミ4X10DB	SCREW PAN (S/P WASHER) M4X10	
51	S38265000	1	ターミナルL	TERMINAL, L	
52	142274101	1	ゴムセン4.2	RUBBER CAP, 4.2	
53	S08003000	1	クミヒモ 4X4	WICK 4X4	
54	SA9793001	1	ビニルチューブ	VINYL TUBE L=160	
55	SA5339101	5	オイルクチパイプ	OIL FEEDING PIPE	
56	SB4570001	2	フェルト	FELT L=230	
57	SB4037001	2	ビニルチューブ	VINYL TUBE	
58	S08003000	1	クミヒモ 4X4	WICK 4X4	
59	SA6576001	1	ビニルチューブ	OIL TUBE L=210	
60	SA4028001	1	クミヒモ4X4 L=220	WICK, 4X4 L=220	
61	S50547000	1	ビニルチューブ	OIL TUBE	

BAS-311H-350

G. 糸通し関係 / Threading mechanism

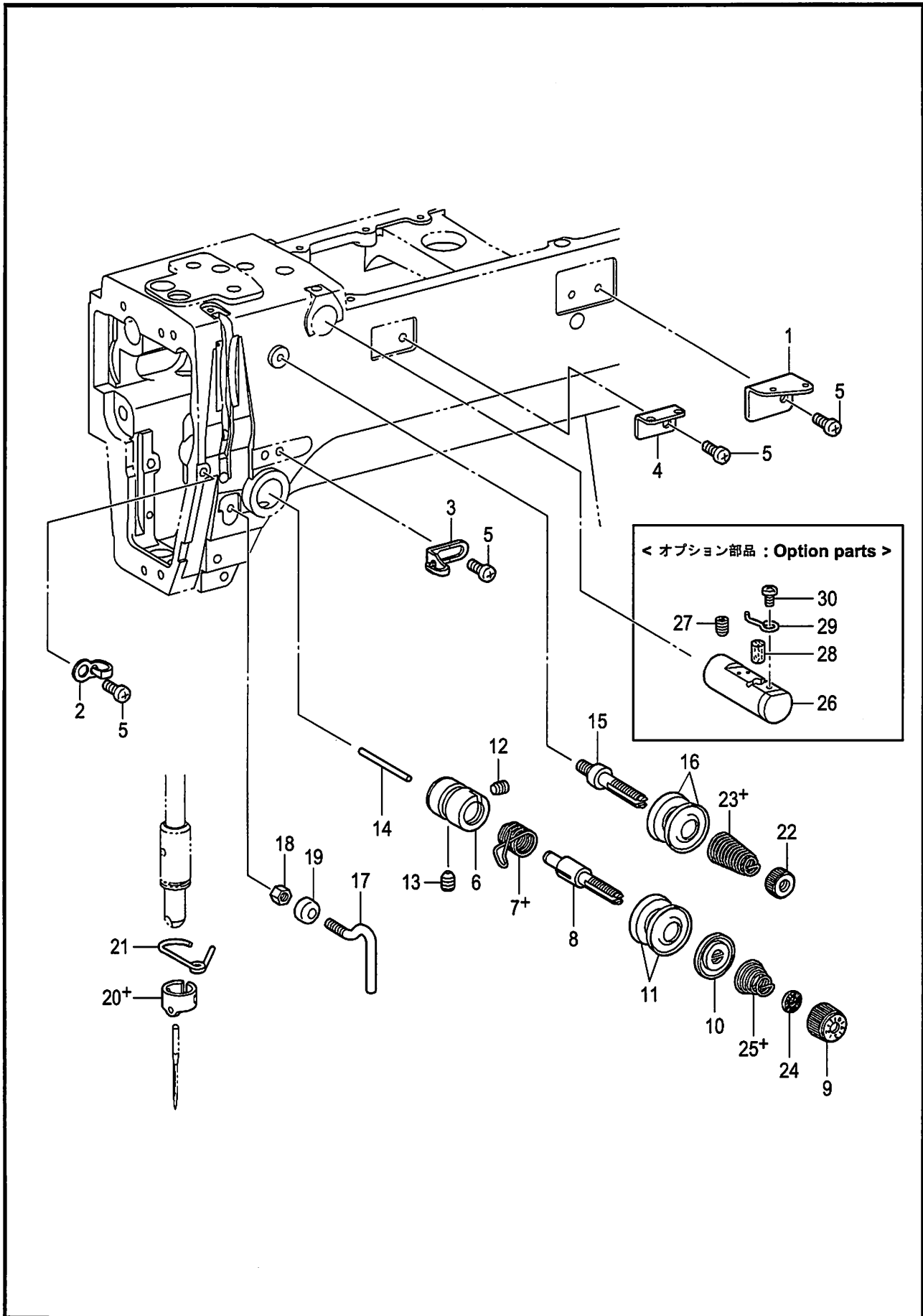

BAS-311H-401



G. 糸通し関係 / Threading mechanism

REF.NO	CODE	Q'TY	品名	NAME OF PARTS	RM
1	SA3250001	1	ア-ムイトミチA	ARM THREAD GUIDE, A	
2	SA4333001	1	ア-ムイトミチB	ARM THREAD GUIDE, B	
3	SA6391001	1	ア-ムイトミチC	ARM THREAD GUIDE C	
4	SB1086001	1	ア-ムイトミチD	ARM THREAD GUIDE D	
5	062500616	4	ナベコ5X6	SCREW PAN M5X6	
6	SA3254001	1	イトチヨウシダイ	TENSION BRACKET	
7+	* P.68	1	イトトリバネ	THREAD TAKE-UP SPRING	
8	SA3255001	1	イトチヨウシボウ	TENSION STUD	
9	S31032002	1	イトチヨウシナツト	TENSION NUT	
10	159805001	1	イトチヨウシサラオサエ	TENSION DISC PRESSER	
11	145446001	2	イトチヨウシサラ	DISC, TENSION	
12	100402004	1	トメネジ3.57	SET SCREW, SM3.57	
13	SA4143001	1	アナトメネジ6	SET SCREW, (FT) M6X6	
14	S12699000	1	イトユルメピン	TENSION RELEASE PIN	
15	SA3256001	1	イトチヨウシボウA	TENSION STUD, A	
16	145446001	2	イトチヨウシサラ	DISC, TENSION	
17	SA8691001	1	ア-ムイトカケ	THREAD GUIDE ARM	
18	021400306	1	3シュナツト4	NUT 3 M4	
19	SA9207001	1	ゴムカバー	RUBBER COVER	
20+	* P.68	1	ハリボウイトアンナイ	NEEDLE BAR THREAD GUIDE	
21	SA3258001	1	ハリボウメタルDイトアンナイ	N-BAR BUSH THREAD GUIDE, D	
22	100136001	1	イトチヨウシナツト	TENSION NUT	
23+	* P.68	1	フクチヨウシバネ	SUB TENSION SPRING	
24+	* P.68	1	チヨウシバネウエザガネ	WASHER	
25+	* P.68	1	イトチヨウシバネ	TENSION SPRING	
			<オプション部品>	<Option parts>	
26	152881101	1	エキレイタイクミ	NEEDLE COOLER ASSY	
27	012060636	1	アナヒラ6X6	SET SCREW SOCKET (FT) M6X6	
28	152883000	1	フェルト8X15.5	FELT, 8X15.5	
29	152884001	1	エキレイイトカケ	NEEDLE COOLER THREAD GUIDE	
30	062670412	1	ナベコ357-40X4	SCREW PAN SM3.57-40X4	

BAS-311H-401

H. 糸巻関係 / Bobbin winder mechanism

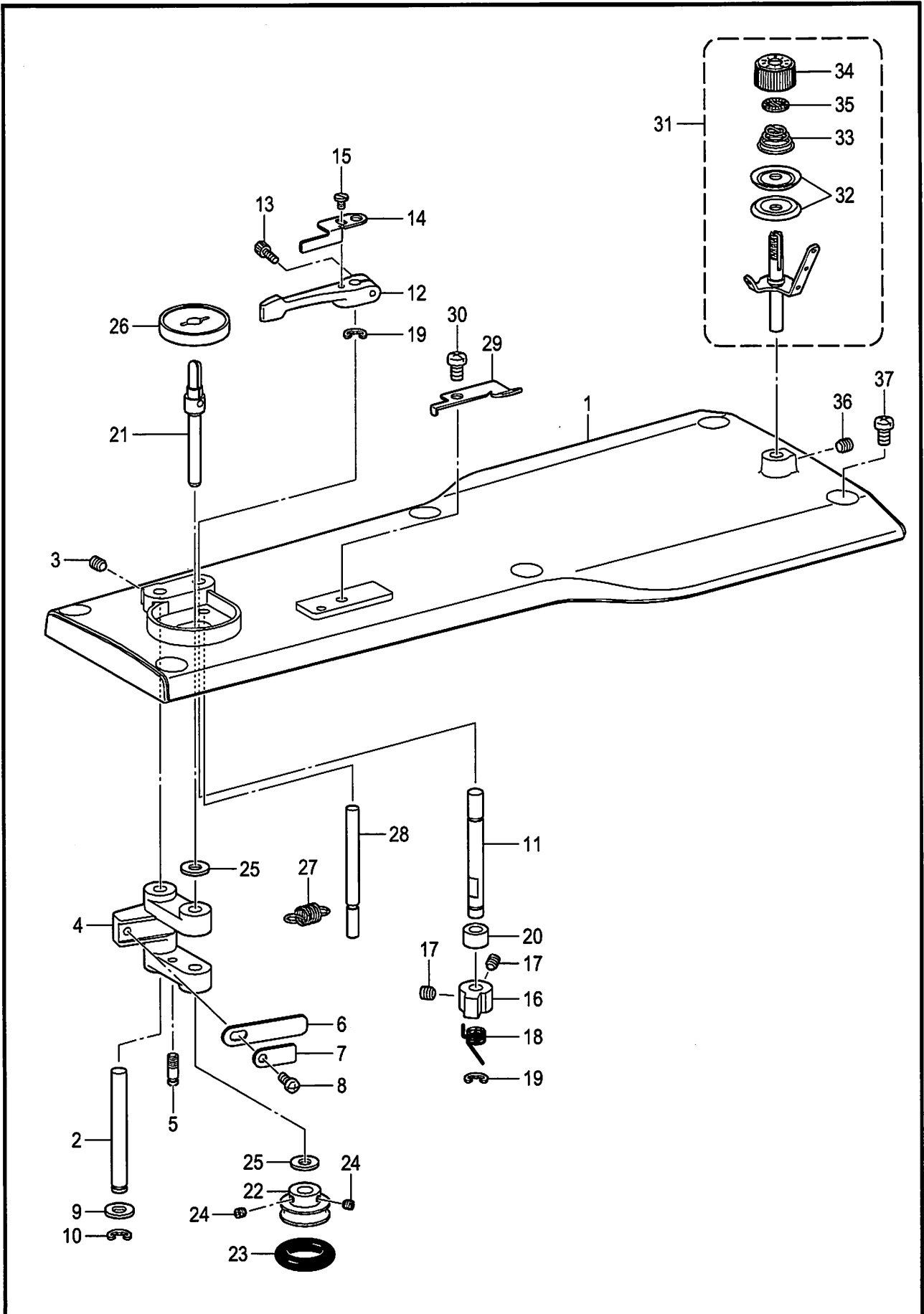

BAS-311H-402

## H. 糸巻関係 / Bobbin winder mechanism

REF.NO	CODE	Q'TY	品名	NAME OF PARTS	RM
1	SB4389001	1	ウフフタ311H	TOP COVER 311H	
2	SA3290001	1	イトマキレバージク	SHAFT, BW-LEVER	
3	012500536	1	アナヒラ5X5	SET SCREW SOCKET (FT) M5X5	
4	SA3291001	1	イトマキレバー	BOBBIN WINDER LEVER	
5	SA4171001	1	バネカケ	SPRING HOOK	
6	152936001	1	イタバネ	PLATE SPRING	
7	152937001	1	ザガネ	WASHER	
8	062350616	1	ナベコ35X6	SCREW PAN M3.5X6	
9	155559021	1	ヒラザガネ	WASHER PLAIN	
10	048050342	1	トメワE5	RETAINING RING E5	
11	SA3293001	1	イトマキツメジク	STUD, B-WINDER CLAW	
12	SA1984001	1	ボビンオサエウデ	BOBBIN PRESSER ARM	
13	018401236	1	アナボルト4X12	BOLT SOCKET M4X12	
14	SA3294001	1	ボビンオサエ	BOBBIN PRESSER	
15	S23418002	1	シメネジ4X5	SCREW, M4X5	
16	SA3295001	1	イトマキツメ	CLAW, B-WINDER	
17	012400436	2	アナヒラ4X4	SET SCREW SOCKET (FT) M4X4	
18	S10438001	1	イトマキツメネジリバネ	SPRING, TWIST	
19	048050342	2	トメワE5	RETAINING RING E5	
20	SA4796001	1	スペーサーカラ	SPACER COLLAR	
21	SA3296001	1	イトマキジク	BOBBIN WINDER SHAFT	
22	SA3297001	1	イトマキクルマ	WHEEL, B-WINDER	
23	120448001	1	ゴムワ	BOBBIN WINDER RUBBER BAND	
24	012400436	2	アナヒラ4X4	SET SCREW SOCKET (FT) M4X4	
25	155559021	2	ヒラザガネ	WASHER PLAIN	
26	SA1988001	1	ボビンウケ	BOBBIN SUPPORT	
27	S10268001	1	イトマキレバーヒキバネ	SPRING	
28	SA3298001	1	ストツパジク	STOPPER SHAFT, B-WINDER	
29	SA3299001	1	メス	KNIFE	
30	062500616	1	ナベコ5X6	SCREW PAN M5X6	
31	SB1253001	1	イトマキチヨウシクミ	BOBBIN WINDER TENSION ASSY	
32	145446002	2	イトチヨウシサラ	DISC, TENSION	
33	100401022	1	イトチヨウシバネ	TENSION SPRING	
34	S31032002	1	イトチヨウシナツト	TENSION NUT	
35	S12441001	1	チヨウシバネウエザガネ	WASHER	
36	012500536	1	アナヒラ5X5	SET SCREW SOCKET (FT) M5X5	
37	062061016	6	ナベコ6X10	SCREW PAN M6X10	

BAS-311H-402

J. 糸切り関係 / Thread trimmer mechanism

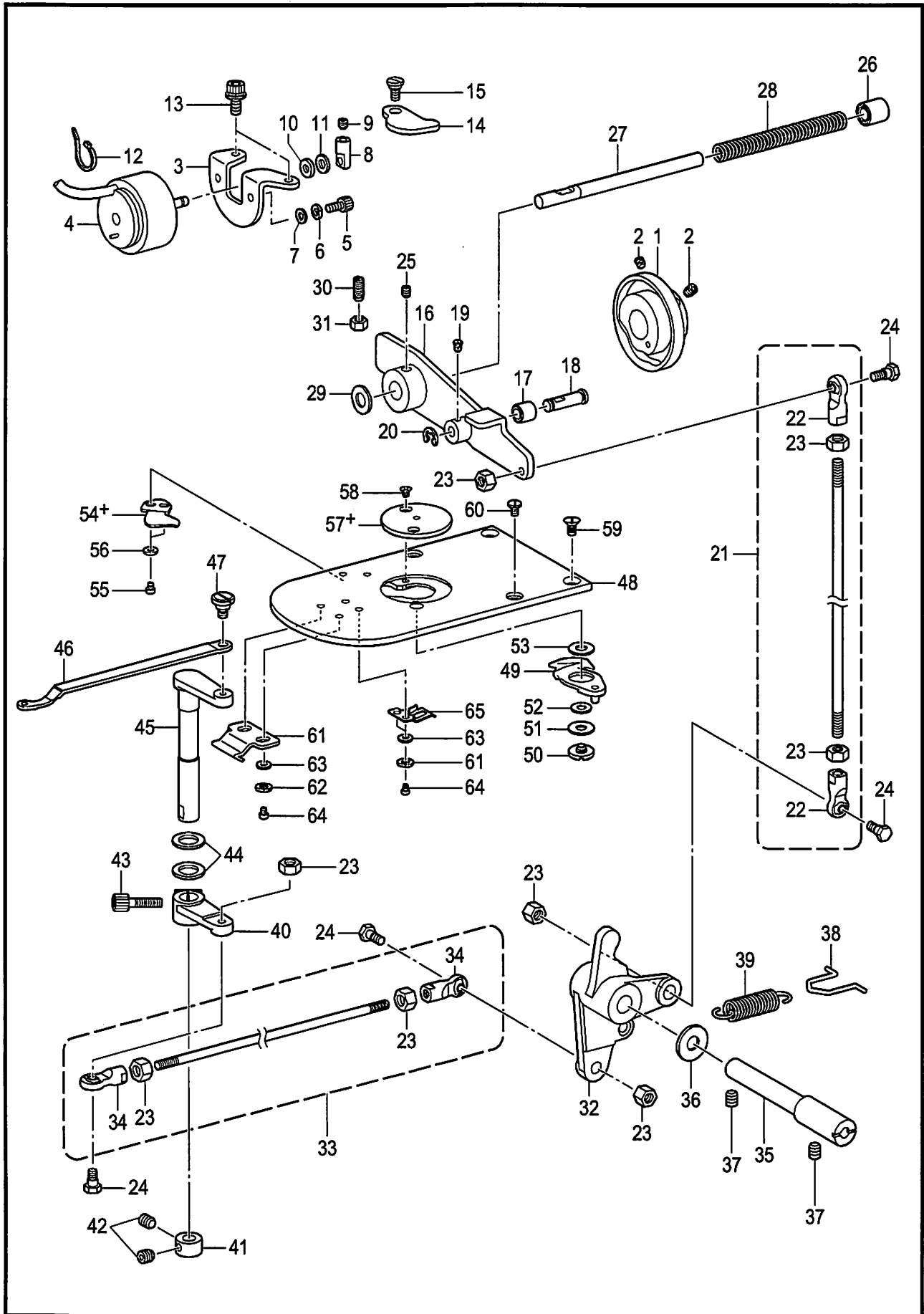

BAS-311H-403

J. 糸切り関係 / Thread trimmer mechanism

REF.NO	CODE	Q'TY	品名	NAME OF PARTS	RM
1	SA4131001	1	イトキリカム	THREAD TRIMMER CAM	
2	S23651001	2	アナヒラ6X6ホソメ	SET SCREW, SOCKET (FT) M6X6	
3	SA4798001	1	ソレノイドトリツケイタ	SETTING PLATE SOLENOID	
4	SA5135101	1	イトキリソレノイド	THREAD TRIMMER SOLENOID	
5	017400802	2	ボルト4X8	BOLT M4X8	
6	028040246	2	バネザガネ2-4	WASHER SPRING 2-4	
7	026040236	2	ヒラザガネミガキ4	WASHER PLAIN M 4	
8	SA3307001	1	ソレノイドレバー	SOLENOID LEVER	
9	012400436	1	アナヒラ4X4	SET SCREW SOCKET (FT) M4X4	
10	154599000	1	ソレノイドクツシヨン	SOLENOID CUSHION	
11	S02652021	1	ザガネ	WASHER	
12	SB4155001	1	バンド	BAND	
13	S55484001	2	アナボルトザクミ5X10	BOLT, SOCKET (S/P WASHER) M5X10	
14	SA4799001	1	クドウレバーオシレバー	PUSHING LEVER D-LEVER	
15	SA3306001	1	ダンネジ7-3	SHOULDER SCREW, 7-3	
16	SA3309201	1	イトキリクドウレバー	TR-DRIVING LEVER	
17	SA3310001	1	イトキリコロ	COLLAR, TR-TRIMMER	
18	SA3311001	1	イトキリコロジク	COLLAR SHAFT	
19	S46903001	1	アタマツキトメネジ4X5	SET SCREW, M4X5	
20	048040342	1	トメワE4	RETAINING RING E4	
21	SB4416001	1	イトキリロッドVクミ	THREAD TRIMMER ROD ASSY V	
22	S32465101	2	タマツギテクミ	BALL JOINT ASSY	
23	021060306	8	3シュナット6	NUT 3 M6	
24	SB4401001	4	ダンネジ6.35-6	SHOULDER SCREW 6.35-6	
25	S23651001	1	アナヒラ6X6ホソメ	SET SCREW, SOCKET (FT) M6X6	
26	231071001	1	メタル8X15	BUSH, 8X15	
27	SA3312201	1	クドウレバーアンナイジク	GUIDE SHAFT	
28	SA3313101	1	クドウジクバネ	SPRING, COMPRESSION	
29	154596000	1	イトキリカムレバークツシヨン	CUSHION	
30	S25475101	1	トメネジ6	SET SCREW, M6X19	
31	021060106	1	1シュナット6	NUT 1 M6	
32	SB4397001	1	イトキリレバー	THREAD TRIMMER LEVER	
33	SB4415001	1	イトキリロッドHクミ	THREAD TRIMMER ROD ASSY H	
34	S32465101	2	タマツギテクミ	BALL JOINT ASSY	
35	SB4399001	1	イトキリレバージク	SHAFT TR-TRIMMER LEVER	
36	SA4545001	1	カンザ	SPACER	
37	012060636	2	アナヒラ6X6	SET SCREW SOCKET (FT) M6X6	
38	SB4398001	1	バネカケ	SPRING HOOK	
39	SA3321001	1	イトキリモドシバネ	SPRING, EXTENSION	
40	SB4395001	1	イドウハレバー	MOVING KNIFE LEVER	
41	SA4588001	1	セットカラー	SET COLLAR	
42	012500536	2	アナヒラ5X5	SET SCREW SOCKET (FT) M5X5	
43	018061636	1	アナボルト6X16	BOLT SOCKET M6X16	
44	SB4400001	2	スラストザガネ	THRUST WASHER	
45	SB4396001	1	イドウハレバージク	SHAFT MOVABLE KNIFE LEVER	
46	SB4394001	1	イドウハレカン	M-KNIFE CONNECTING PLATE	
47	SA4354001	1	ダンネジ6-1.8	SHOULDER SCREW, 6-1.8	

BAS-311H-403

J. 糸切り関係 / Thread trimmer mechanism

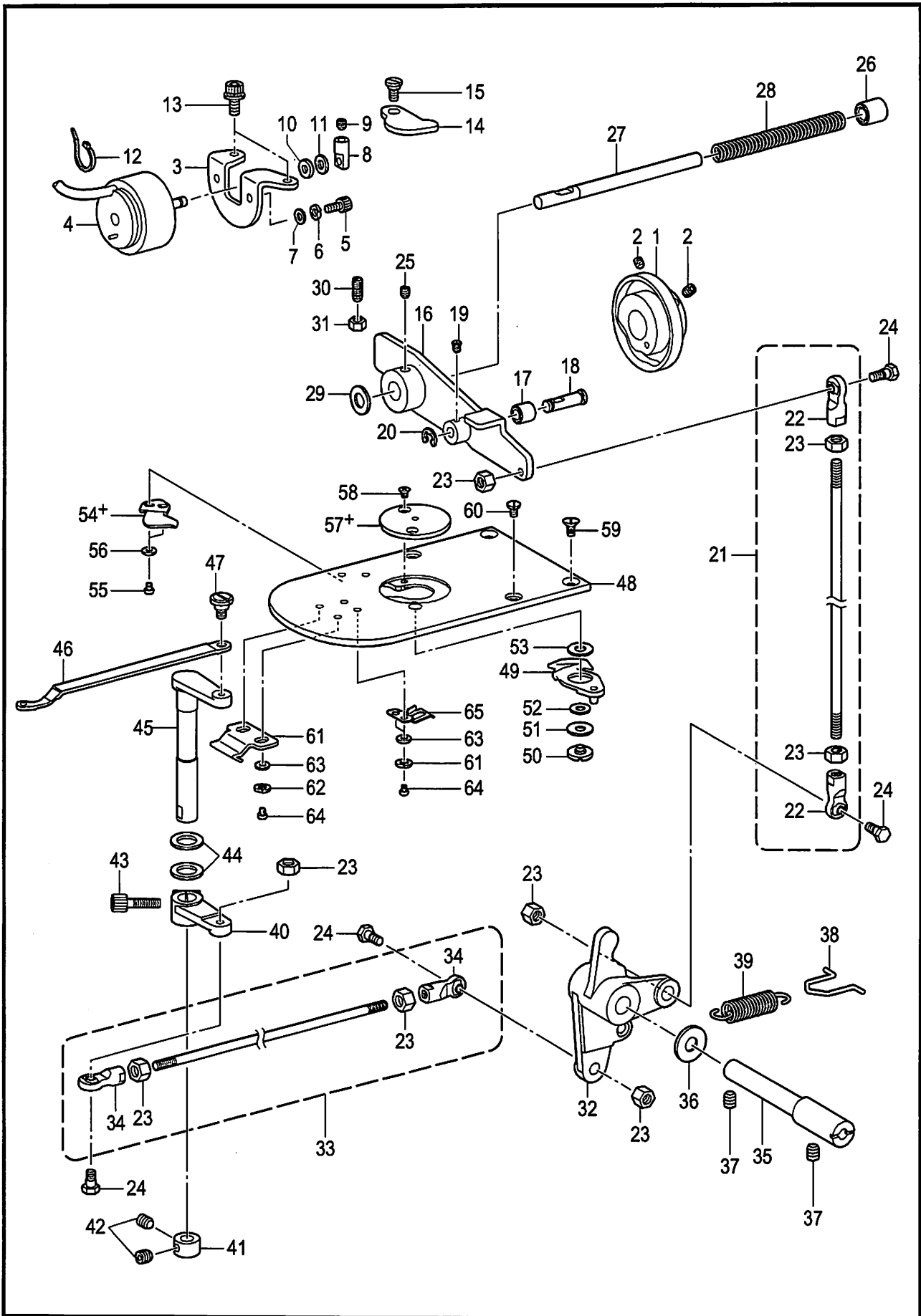

BAS-311H-403

J. 糸切り関係 / Thread trimmer mechanism

REF.NO	CODE	QTY	品名	NAME OF PARTS	RM
48	SB4595001	1	ハリイタ	NEEDLE PLATE	
49	SB2439001	1	イドウハフクミ	MOVABLE KNIFE ASSY F	
50	SA4518001	1	イドウハダンネジ	MOVABLE KNIFE SHOULDER SCREW	
51	SA4519001	1	スラストザガネ	THRUST WASHER	
52	S00705001	1	イドウハカラ-	MOVABLE KNIFE COLLAR	
53	SA6397001	1	イドウハカンザ0.2	M-KNIFE SPACER T0.2	
53	SA3334001	1	イドウハカンザ0.3	M-KNIFE SPACER T0.3	
53	SA6398001	1	イドウハカンザ0.4	M-KNIFE SPACER T0.4	
54+	* P.67	1	コテイハ	FIXED KNIFE	
55	062300416	2	ナベコ3X4	SCREW PAN M3X4	
56	SB3847001	2	ヒラザガネチュウ3	WASHER_PLAIN_M_3	
57+	* P.67,69	1	ハリアナイタ	NEEDLE HOLE PLATE	
58	100360003	2	サラネジ2.38	SCREW	
59	S25310101	2	サラネジ4	SCREW, FLAT M4	
60	SA3538001	2	シメネジ4X8	SCREW, M4X8	
61	SA6273101	1	オオカマカバーフックU	SHUTTLE RACE COVER HOOK U	
62	028030246	4	バネザガネ2-3	WASHER SPRING 2-3	
63	SB3847001	4	ヒラザガネチュウ3	WASHER_PLAIN_M_3	
64	062300416	4	ナベコ3X4	SCREW PAN M3X4	
65	SB0713001	1	シタイトオサエバネ	BOBBIN THREAD CLAMP SPRING	

BAS-311H-403

K. 糸払い関係 / Thread wiper mechanism

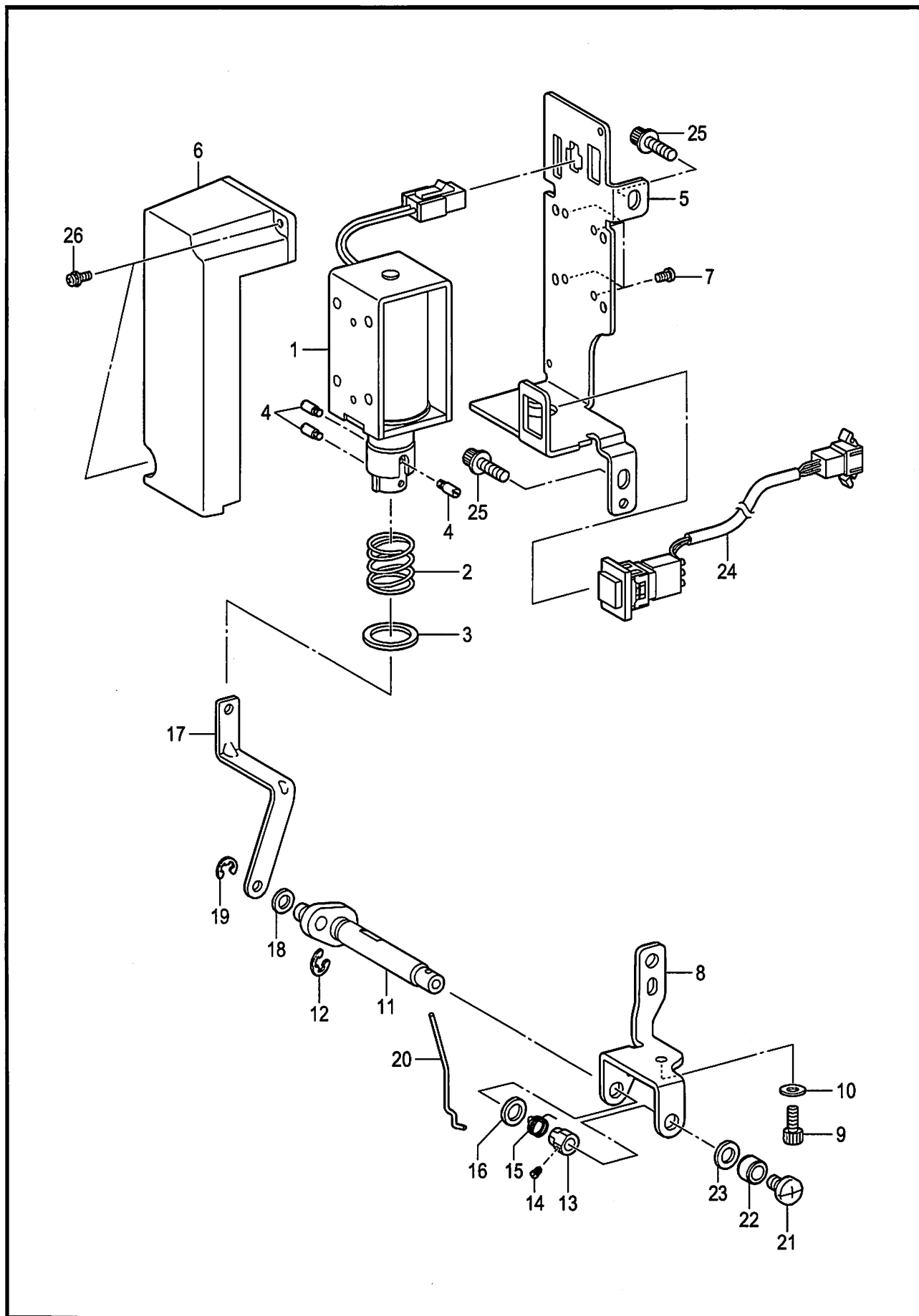

BAS-311H-405



K. 糸払い関係 / Thread wiper mechanism

REF.NO	CODE	Q'TY	品名	NAME OF PARTS	RM
1	SB4297101	1	イトハライソレノイドクミ	THREAD WIPER SOLENOID ASSY	
2	S41206001	1	イトハライバネ	THREAD WIPER SPRING	
3	S41205001	1	ヒラザガネ	WASHER, PLAIN	
4	S25456021	3	プランジャピン	PLUNGER PIN	
5	SB4379001	1	イトハライソレノイドトリツケイタ	T-WIPER SOLENOID SETTING PLATE	
6	SA4806101	1	ソレノイドカバー	SOLENOID COVER	
7	062300616	4	ナベコ3X6	SCREW PAN M3X6	
8	SB4378001	1	イトハライジクウケイタ	THREAD WIPER SHAFT BRACKET	
9	018400836	1	アナボルト4X8	BOLT SOCKET M4X8	
10	SB3848001	1	ヒラザガネチュウ4	WASHER_PLAIN_M_4	
11	SA8057001	1	イトハライクランククミ	THREAD WIPER CRANK ASSY	
12	048040342	1	トメワE4	RETAINING RING E4	
13	S25454021	1	セットカラー	SET SCREW COLLAR	
14	S25279101	1	アタマトメクボM35-5	SET SCREW (CP) M3.5-5	
15	SA2287001	1	ワイパーバネ	SPRING	
16	149097000	1	シヨウオンシート	SILENT SHEET	
17	SA5219001	1	イトハライロッド	THREAD WIPER ROD	
18	110735022	1	ザガネ	WASHER	
19	048030342	1	トメワE3	RETAINING RING E3	
20	S10470201	1	ワイパー	WIPER	
21	060400516	1	バインド4X5	SCREW BIND M4X5	
22	146288021	1	イトハライジクカラー	THREAD WIPER STUD COLLAR	
23	S03677001	1	ザガネ	WASHER	
24	SA5213001	1	テイシSWクミ	STOP SWITCH ASSY	
25	S55485001	2	アナボルトザクM5X12	BOLT, SOCKET (S/P WASHER) M5X12	
26	0A4300806	2	+ナベザクM3X8DA	SCREW PAN (S/P WASHER) M3X8	

BAS-311H-405

L. 糸緩め関係 / Tension release mechanism

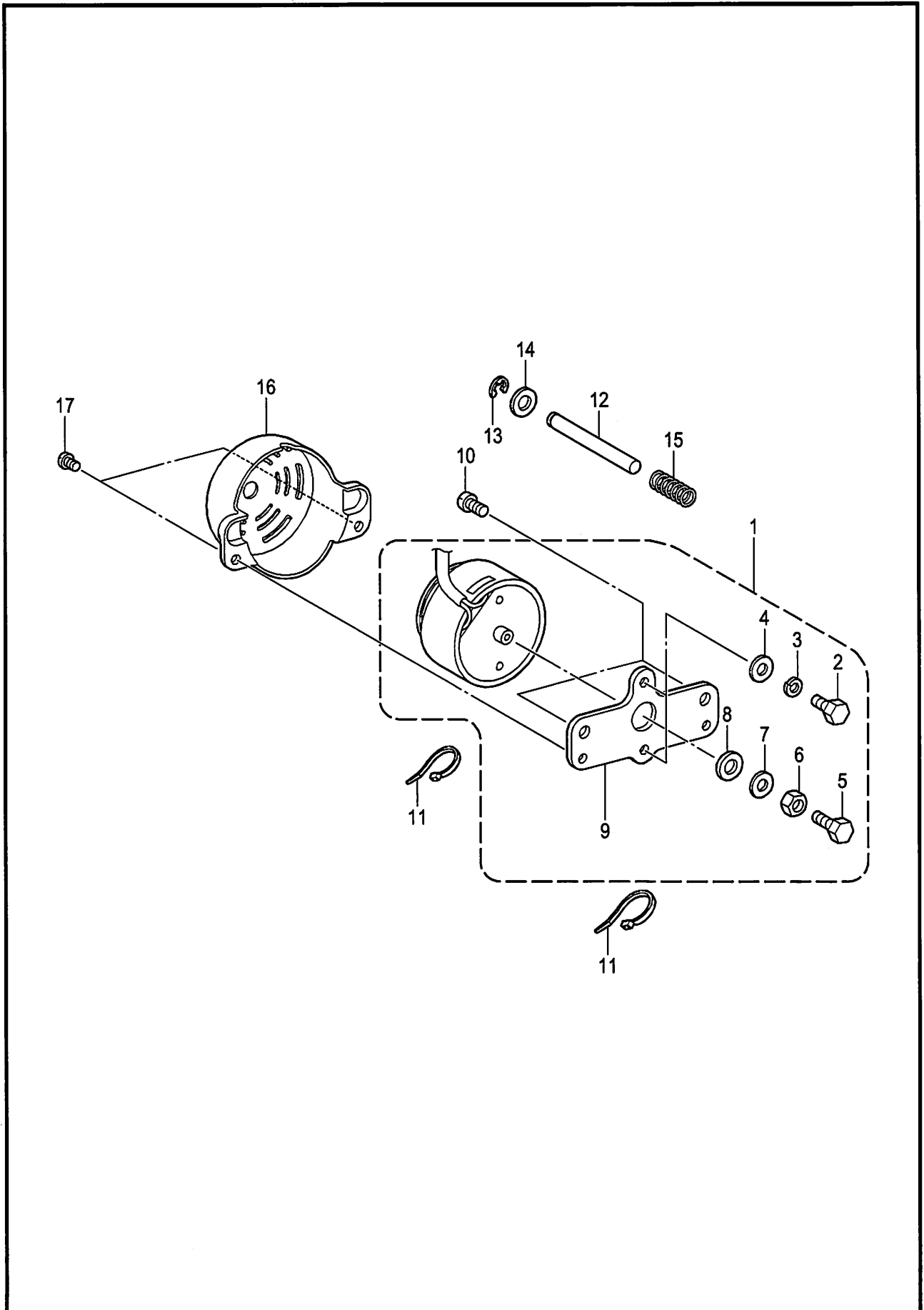

BAS-311H-406

## L. 糸緩め関係 / Tension release mechanism

REF.NO	CODE	Q'TY	品名	NAME OF PARTS	RM
1	SB4467001	1	イトユルメクミ	TENSION RELEASE ASSY	
2	017400802	2	ボルト4X8	BOLT M4X8	
3	028040246	2	バネザガネ2-4	WASHER SPRING 2-4	
4	026040236	2	ヒラザガネミガキ4	WASHER PLAIN M 4	
5	017401415	1	ボルト4X14	BOLT M4X14	
6	021400306	1	3シュナット4	NUT 3 M4	
7	102707002	1	ザガネ	WASHER	
8	154599000	1	ソレノイドクツシヨン	SOLENOID CUSHION	
9	SB4380001	1	ソレノイドトリツケイタ	SETTING PLATE SOLENOID	
10	062500816	2	ナベコ5X8	SCREW PAN M5X8	
11	SB4155001	2	バンド	BAND	
12	SA3347001	1	イトユルメボウ	TENSION RELEASE BAR	
13	048040342	1	トメワE4	RETAINING RING E4	
14	SB3849001	1	ヒラザガネチュウ5	WASHER_PLAIN_M_5	
15	SA3348001	1	コイルバネ	SPRING, COMPRESSION	
16	SB0787001	1	ソレノイドカバー	SOLENOID COVER	
17	060400516	2	バインド4X5	SCREW BIND M4X5	

BAS-311H-406

M1.コントロールボックス関係 / Control box

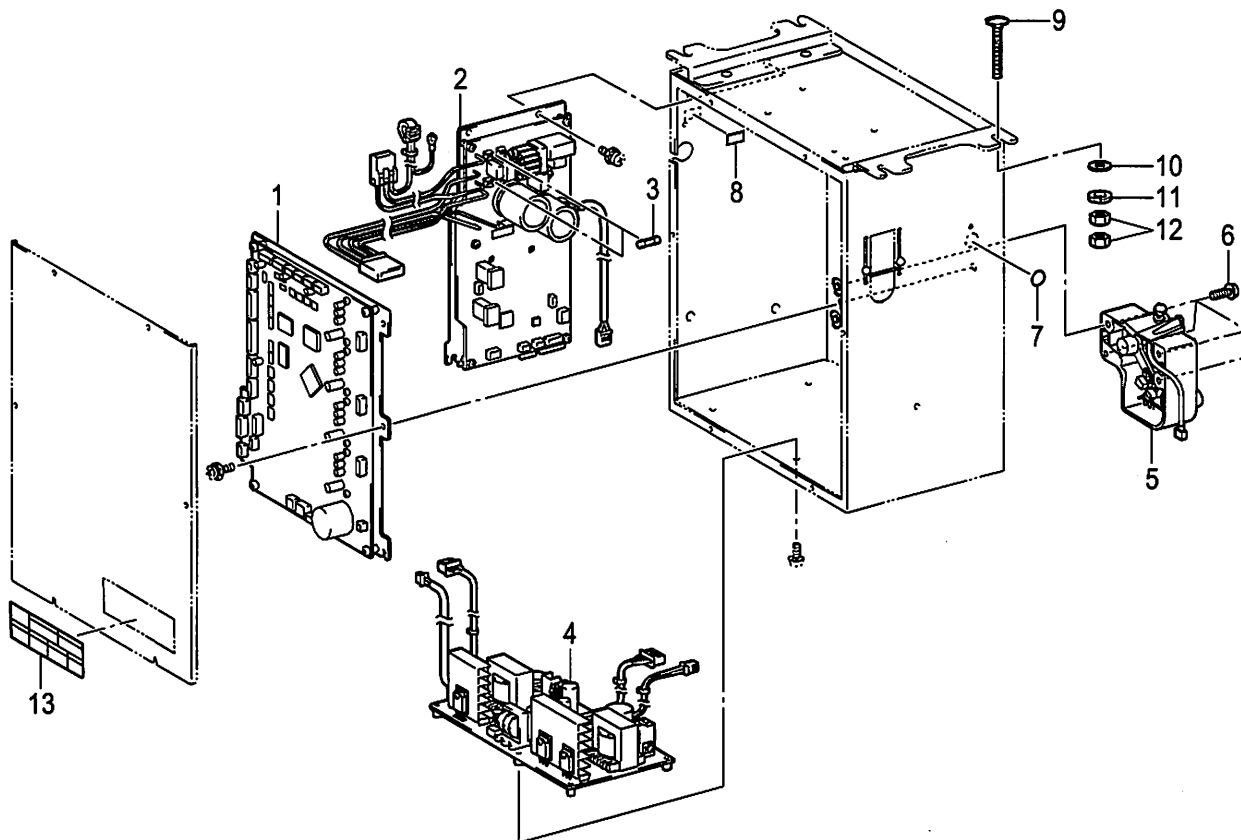
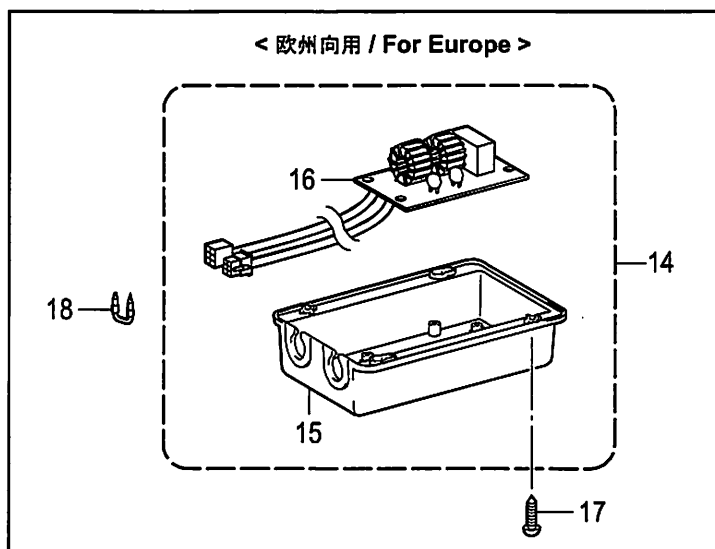

BAS-311H-502

M1. コントロールボックス関係 / Control box

REF.NO	CODE	Q'TY	品名	NAME OF PARTS	RM
1	SB4540101	1	メインキバンクミ 311H	MAIN PCB ASSY 311H	
2	SB4541001	1	モータキバンクミ 311H	MOTOR PCB ASSY 311H	
3	J04417001	2	Gヒューズ10A-250V	G FUSE 10A-250V:FGMB	
4	SA9500201	1	デンゲンキバンクミ	POWER PCB ASSY	
5	SA9602101	1	フミコミニット-ユ	TREADLE UNIT -EX	
6	J00353001	4	+ナベセット5X14DB	SCREW PAN (S/P WASHER) M5X14	
7	S37060001	1	ア-スマーク	LABEL, GROUNDING	
8	S37059001	1	PEマーク	LABEL, PE	
9	SA9893001	4	カクネボルト8X65	BOLT M8X65	
10	025080336	4	ヒラザガネダイ8	WASHER PLAIN L 8	
11	028080246	4	バネザガネ2-8	WASHER SPRING 2-8	
12	021080206	4	2シュナット8	NUT 2 M8	
13	SA9725001	1	ラベルカンデン6カコク	LABEL ELECTRICAL SHOCK 36X150	
			<欧州向用>	<For Europe>	
14	SA9559001	1	CE フィルタ クミ	CE FILTER BOX ASSY	
15	SA9564001	1	CEフィルターケース	CE FILTER CASE	
16	SA9565001	1	CEフィルターキバンクミ	CE FILTER PCB ASSY	
17	S03816001	4	+マルモク45X16	WOOD SCREW M4.5X16	
18	200190001	5	ステツブル 10X20	STAPLE 10X20	

BAS-311H-502

M2. コントロールボックス関係 / Control box

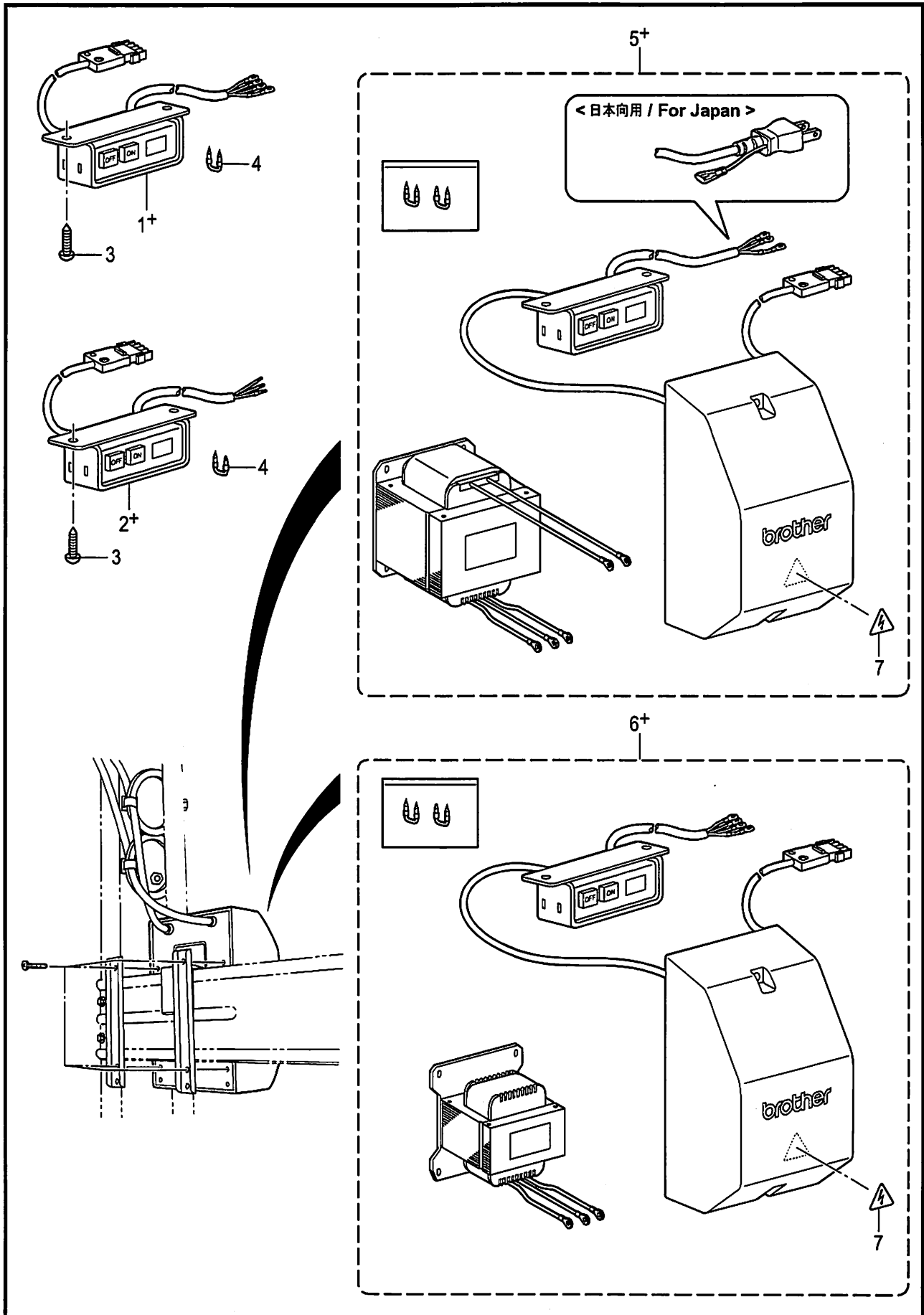

BAS-311H-502

M2. コントロールボックス関係 / Control box

REF.NO	CODE	Q'TY	品名	NAME OF PARTS	RM
1+	SA9616001	1	<三相 200V AC 用> <日本向用> デンSW クミ SJT	<For Three phase 200V AC> <For Japan> POWER SWITCH ASSY SJT	
1+	SA9831001	1	<三相 220V AC 用> <米州向用> デンSW クミ SJT#2	<For Three phase 220V AC> <For the Americas> POWER SWITCH ASSY SJT#2	
2+	SA9535001	1	<単相 220V AC用> <アジア・一般・欧州向用> デンSWクミCCC	<For Single phase 220V AC> <For Asia, General and Europe> POWER SUPPLY SWITCH ASSY CCC	
2+	BMP3010-0000001-3S00	1	<単相 220V AC用> <中国向用> デンゲンSW 220V	<For Single phase 220V AC> <For China> POWER SWITCH 220V	
3	S03816001	2	+マルモク45X16	WOOD SCREW M4.5X16	
4	200190001	2	ステツブル 10X20	STAPLE 10X20	
5+	SB1229001	1	<単相 100V用> <日本向用> トランスボックスホキユウクミ	<For Single phase 100V> <For Japan> TRANCE BOX 100V SUPPLY	
5+	BMP3010-0000000-2ST1	1	<米州向用> トランスボックス	<For the Americas> TRANSFORMER BOX	
6+	BMP3010-0000000-3ST4	1	<三相 380V用> <アジア・一般向用> トランスボックス	<For Three phase 380V> <For General and Asia> TRANSFORMER BOX	
6+	BMP3010-0000001-3ST4	1	<中国向用> トランスボックス	<For China> TRANSFORMER BOX	
6+	BMP3010-0000000-4ST4	1	<三相 400V用> <欧州向用> トランスボックス	<For Three phase 400V> <For Europe> TRANSFORMER BOX	
7	SA9914001	1	ラベルカンデン 25 X 28	LABEL ELECTRICAL SHOCK 25 X 28	

BAS-311H-502

N. 空圧関係 (-0□A) / Air pressure mechanism (-0□A)

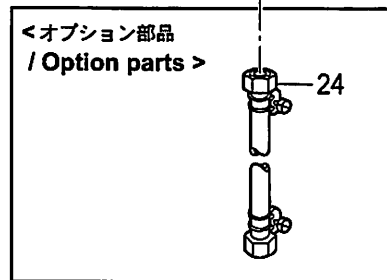
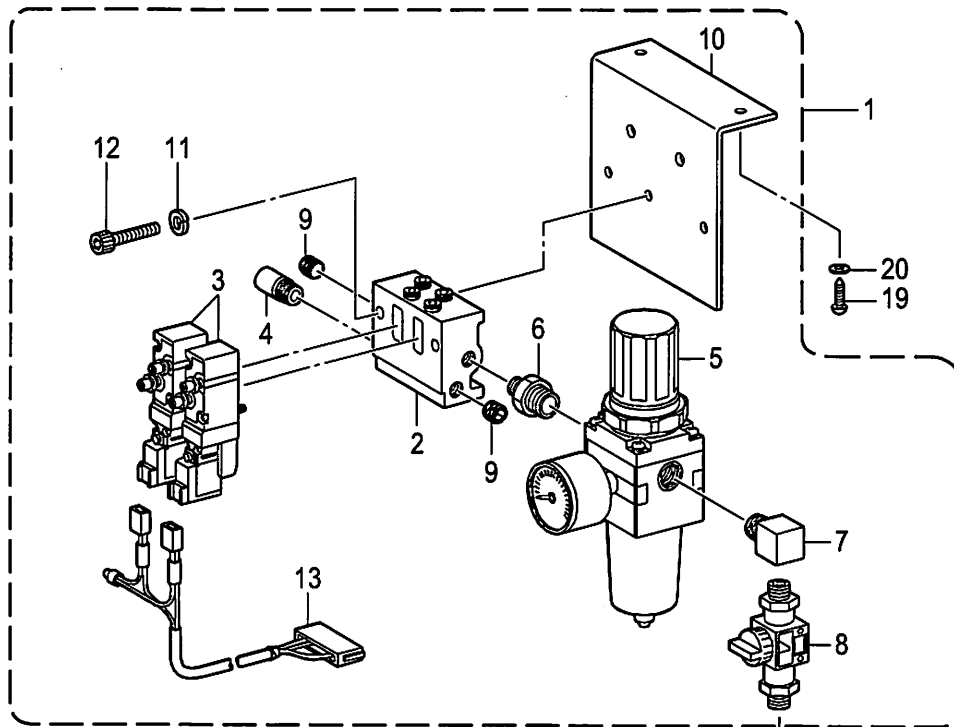
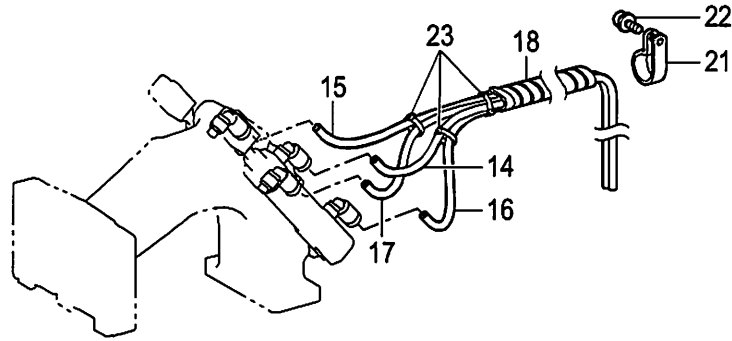



N. 空圧関係 (-0□A) / Air pressure mechanism (-0□A)

REF.NO	CODE	Q'TY	品名	NAME OF PARTS	RM
1	SA5281201	1	デンジバルブ2Aクミ	SOLENOID VALVE ASSY 2A	
2	SA5289001	1	マニホールド2	MANIFOLD2	
3	S39116100	2	バルブVQZ2151S-5	VALVE VQZ2151S-5	
4	SA5283001	1	サイレンサ AN10-1	SILENCER AN10-1	
5	SA5282001	1	レギュレータ AW20-02G	FILTER REGULATOR AW20-02G	
6	S09228000	1	イケイニツプル	NIPPLE 1/4X1/8	
7	SA7588001	1	PTエルボ1/4	ELBOW PT 1/4	
8	SB0445001	1	フィンガーバルブ	FINGER VALVE	
9	153274001	2	1/8トメセン	CAP, 1/8	
10	SA5286101	1	バルブトリツケイタ	SETTING PLATE VALVE	
11	028050246	2	バネザガネ2-5	WASHER SPRING 2-5	
12	018503036	2	アナボルト5X30	BOLT SOCKET M5X30	
13	SA5191001	1	バルブハーネス2レンクミ	VALVE HARNESS X2 ASSY	
14	SA6405001	1	ナイロンチューブR	AIR TUBE R	
15	SA6406001	1	ナイロンチューブL	AIR TUBE L	
16	SA6405002	1	ナイロンチューブR	AIR TUBE R	
17	SA6406002	1	ナイロンチューブL	AIR TUBE L	
18	SA6407001	1	スパイラル470S	SPIRAL,470S	
19	032422003	2	+2マルモク41X20	WOOD SCREW, ROUND 2 M4.1X20	
20	148847001	2	ザガネ	WASHER PLAIN 4.76	
21	525664000	1	コードホルダ#6	CORD HOLDER #6	
22	0A5401006	1	+ナベザクミ4X10DB	SCREW PAN (S/P WASHER) M4X10	
23	228475000	3	ケツソクバンド1.9X80	FASTENING BAND 1.9X80	
			<オプション部品>	<Option parts>	
24	149796001	1	ゴムホースカナグツキ	AIR HOSE W/CONNECTOR	

BAS-311H-514

P. 電装品関係 / Power supply equipment

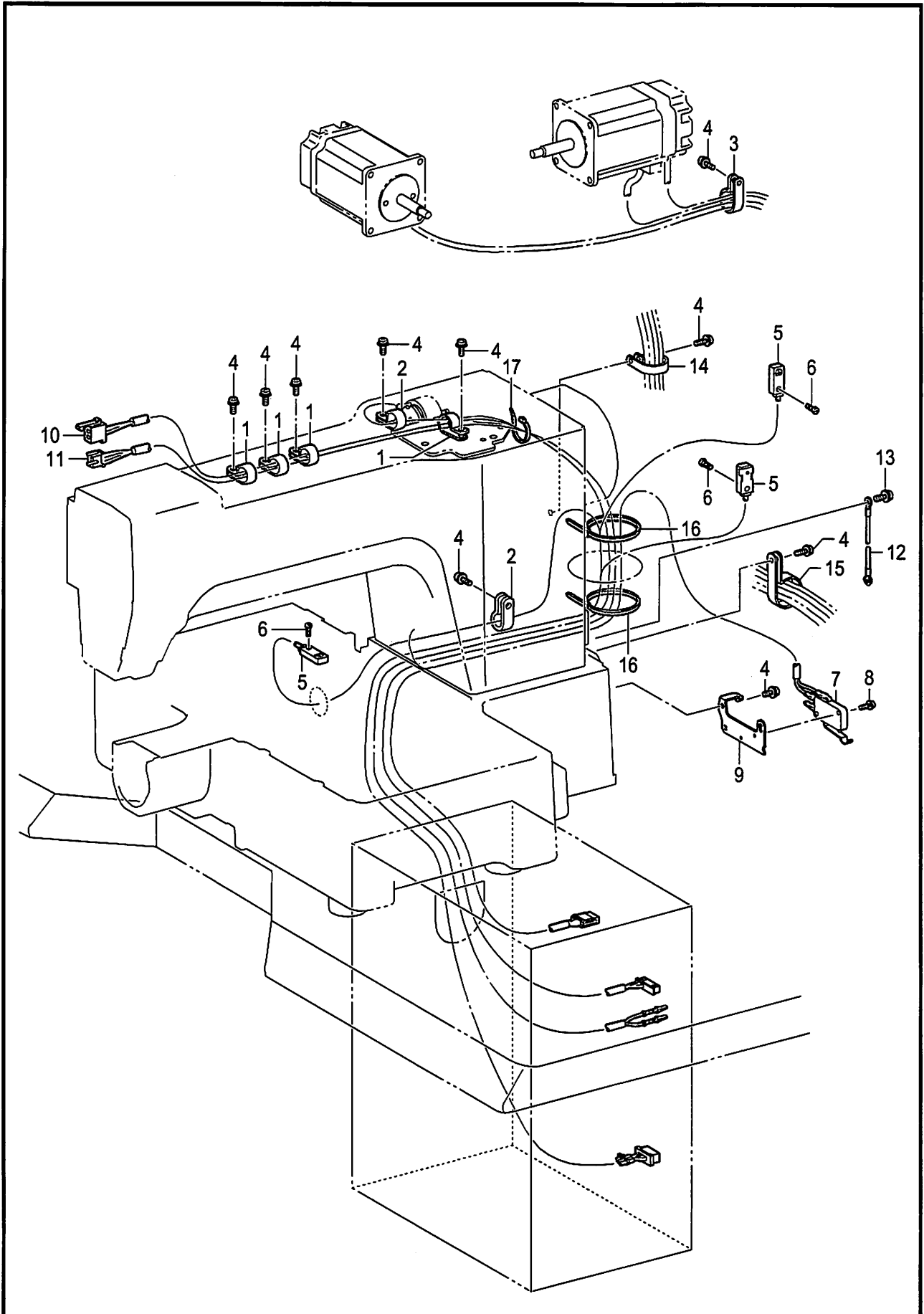

BAS-311H-515

P. 電装品関係 / Power supply equipment

REF.NO	CODE	QTY	品名	NAME OF PARTS	RM
1	525567000	4	コードホルダ#8	CORD HOLDER, #8	
2	149547000	2	コードオサエ	CORD HOLDER, 4N	
3	149287000	1	ナイロンクランプ	CORD HOLDER, 7N	
4	0A5401006	10	+ナベザクミ4X10DB	SCREW PAN (S/P WASHER) M4X10	
5	SB4260001	1	ゲンテンセンサクミ	H-POSITION SENSOR ASSY	
6	062300816	3	ナベコ3X8	SCREW PAN M3X8	
7	SB4296001	1	トウブSWクミ	SWITCH ASSY MACHINE HEAD	
8	0A5301605	2	+ナベザクミ3X16DB	SCREW PAN (S/P WASHER) M3X16	
9	SB1200101	1	トウブSWトリツケイタ	SWITCH MACHINE HEAD PLATE	
10	SA5210001	1	イトハライソレノイドハーネス	THREAD WIPER SOLENOID HARNESS	
11	SB4259001	1	テイシSWハーネス	STOP SWITCH HARNESS 311H	
12	SB4261001	1	アースセン	GROUND WIRE HEAD-BOX	
13	0A5401006	1	+ナベザクミ4X10DB	SCREW PAN (S/P WASHER) M4X10	
14	SB4096001	1	コードホルダ#12	CORD HOLDER, #12	
15	S00470000	1	コードホルダ#16	CORD HOLDER, 16N	
16	218859001	2	バインダM150	BINDER, M150	
17	SB4155001	1	バンド	BAND	

BAS-311H-515

Q. モーター・操作パネル関係 / Motor mechanism and operation panel

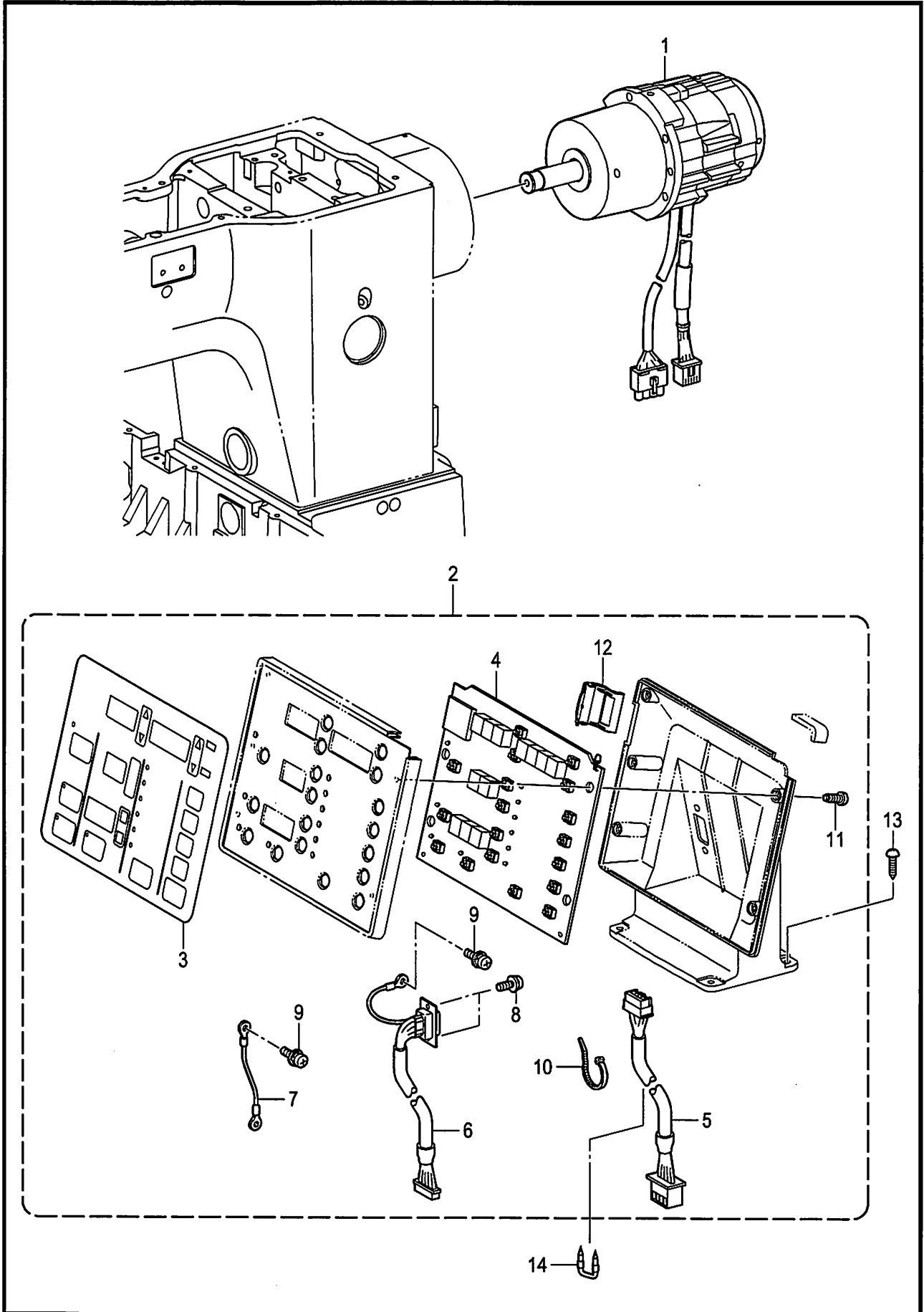

BAS-311H-650

Q. モーター・操作パネル関係 / Motor mechanism and operation panel

REF.NO	CODE	Q'TY	品名	NAME OF PARTS	RM
1	SB0752101	1	モータ430ホキユウ	MOTOR 430 SUPPLY	
2	SB4546101	1	ソウサパネルクミ 311H	OPERATION PANEL ASSY 311H	
3	SB4547001	1	ソウサパネルシート 311H	PANEL SHEET 311H	
4	SB4549001	1	パネルキバンクミ 311H	PANEL PCB ASSY 311H	
5	SB0553001	1	パネルハーネス	PANEL HARNESS	
6	SA4837101	1	プログラマチュウケイハーネス	PROGRAMMER CONNECTING HARNESS	
7	SA4841101	1	アースセン	GROUND WIRE	
8	0A4400806	2	+ナベザクミ4X8DA	SCREW PAN (S/P WASHER) M4X8	
9	0A4400806	2	+ナベザクミ4X8DA	SCREW PAN (S/P WASHER) M4X8	
10	220681001	1	ケツソクバンド2.2X85	CABLE TIE	
11	085311016	5	バインドBタイト3X10	TAPTITE BIND B M3X10	
12	SB0566001	1	カードカバー	CARD COVER	
13	0B0452006	4	+マルモク45X20	WOOD SCREW ROUND M4.5X20	
14	200190001	3	ステツブル 10X20	STAPLE 10X20	

BAS-311H-650

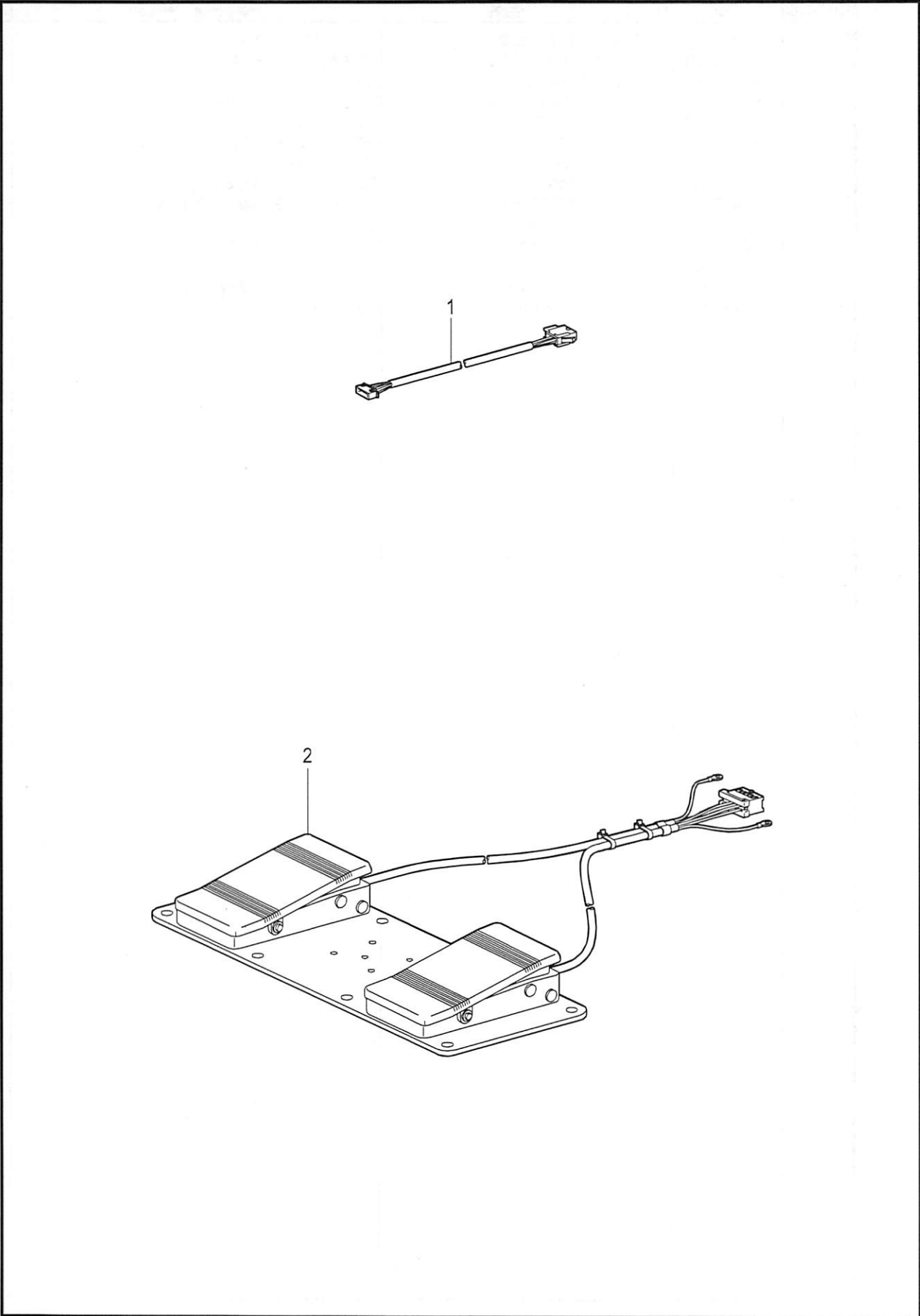

R. 踏板関係 (オプション部品) / Foot switch pedal mechanism (Option parts)

REF.NO	CODE	Q'TY	品名	NAME OF PARTS	RM
1	SB1565001	1	フットSWヘンカンハーネス	CONVERSION HARNESS FOOT SW	
2	SA6038001	1	2レンフットSWクミ	2-PEDAL FOOT SWITCH ASSY	

BAS-311H-651

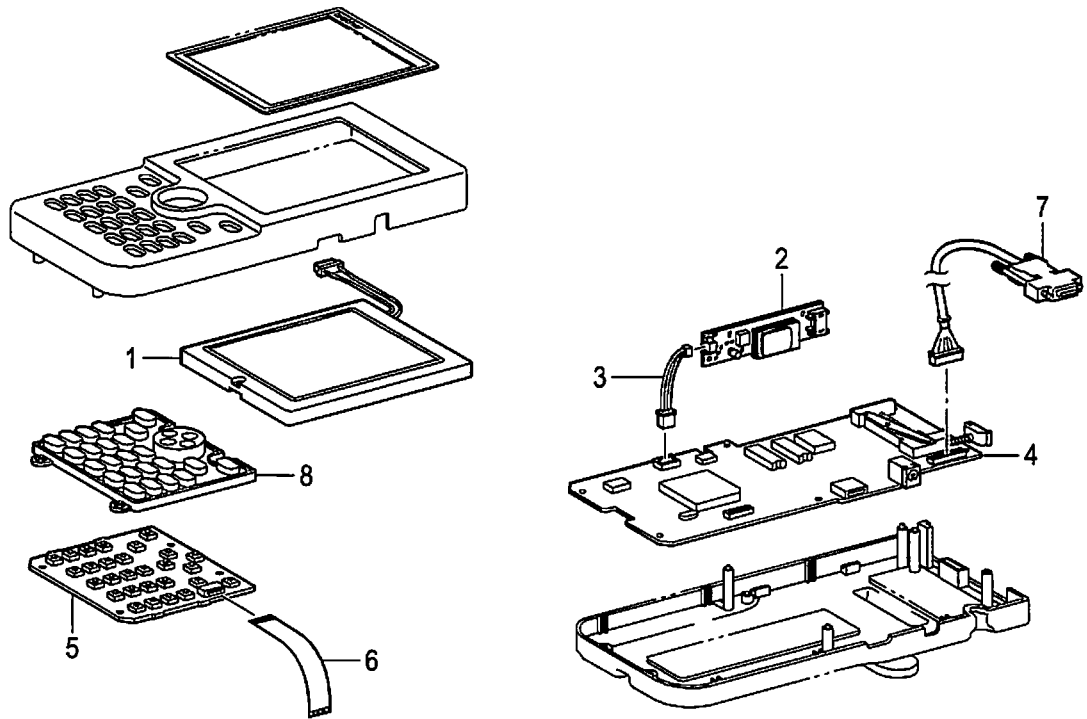



S. プログラム関係 / Programmer

REF.NO	CODE	Q'TY	品名	NAME OF PARTS	RM
1	SA5164101	1	LCDモジュール	LCD MODULE	
2	SA5165001	1	LCDインバーター	LCD INVERTER	
3	SA5166001	1	インバーターハーネス	INVERTER HARNESS	
4	SB4573001	1	プログラマキバンクミ	PROGRAMMER PCB ASSY	
5	SA5172001	1	スイッチキバンクミ	SWITCH PCB ASSY	
6	XD1115051	2	FFCハーネス	FFC: SML2CD	
7	SA5167001	1	プログラマハーネス	PROGRAMMER HARNESS	
8	SA4574001	1	キーボード	KEYBOARD	

BAS-311H-940

T1. 付属装置関係(オプション部品) / Attachment set (Option parts)

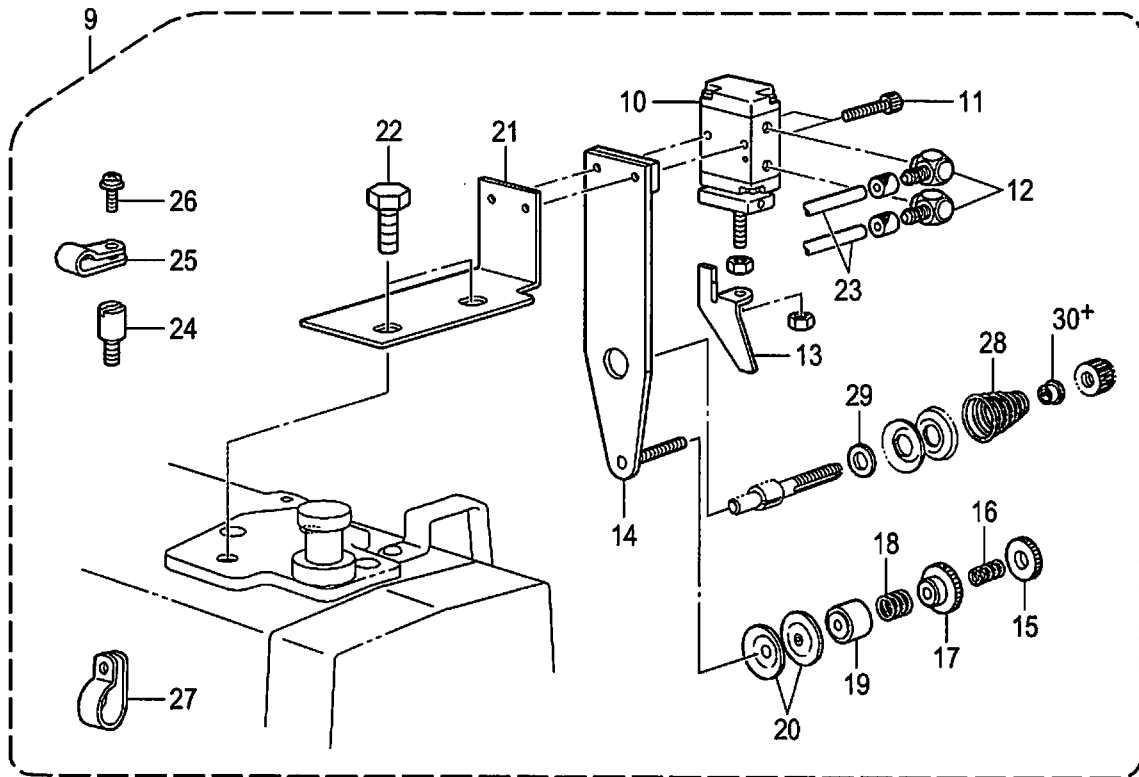
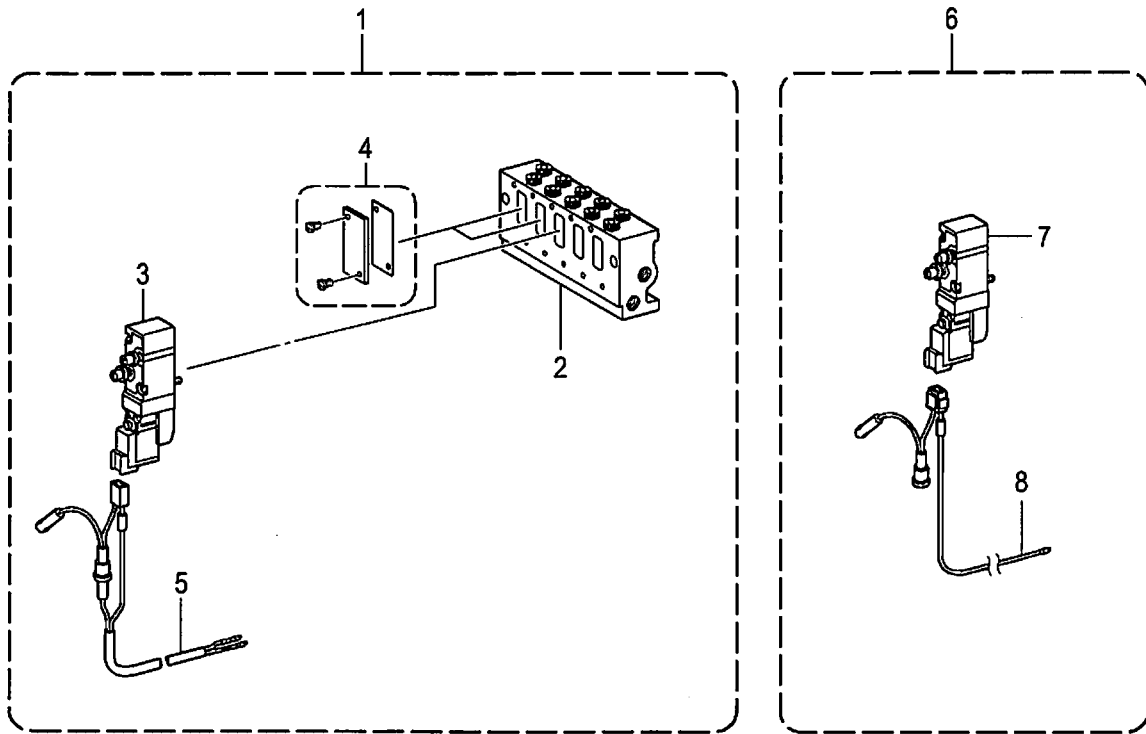

T1. 付属装置関係 (オプション部品) / Attachment set (Option parts)

REF.NO	CODE	Q'TY	品名	NAME OF PARTS	RM
1	SA7500001	1	OPマニホールド5セット	OPTION MANIFOLD 5 SET	
2	SA5290001	1	マニホールド5	MANIFOLD 5	
3	S39116100	1	バルブVQZ2151S-5	VALVE VQZ2151S-5	
4	S53982000	2	ブランキングプレートクミ	BLANKING PLATE ASSY	
5	SA7166101	1	バルブハーネスX1クミ	VALVE HARNESS ASSY X1	
6	SA7171001	1	OPツイカバルブクミ	OPTION ADD VALVE ASSY	
7	S39116100	1	バルブVQZ2151S-5	VALVE VQZ2151S-5	
8	SA7167101	1	ツイカバルブハーネスSG	OP VALVE HARNESS SG	
9	SA7197101	1	2ダンテンションソウチ	2-STEP THREAD TENSION DEVICE	
10	S34706000	1	エア-シリンダ10X10	AIR CYLINDER, 10X10	
11	018302036	2	アナボルト3X20	BOLT SOCKET M3X20	
12	S12150000	2	ホ-スエルボM-5HL-4	TUBE ELBOW, M-5HL-4	
13	S34533001	1	サラワリツメ	COUNTERSINK CLAW	
14	S34534101	1	サブテンションダイクミ	SUB TENSION BRACKET ASSY	
15	155510001	1	イトチョウシナツト	TENSION NUT	
16	146060000	1	ナットオシバネ	SPRING	
17	146059001	1	プレテンションナツト	PRE-TENSION NUT	
18	146058001	1	プレテンションバネ	PRE-TENSION SPRING	
19	146206009	1	イトアンナイサラオサエ	DISC PRESSER, T-GUIDE	
20	144504001	2	イトアンナイサラ	THREAD GUIDE DISC	
21	SA7199001	1	シリンダトリツケイタ	SETTING BRACKET, CYLINDER	
22	017081606	2	ボルト8X16	BOLT M8X16	
23	S15031010	2	エア-チューブ	AIR TUBE, 4X2.5	
24	SA7155001	2	スペ-サ	SPACER	
25	S00480000	2	コードホルダ#5	CORD HOLDER, 5N	
26	0A5401006	2	+ナベザクミ4X10DB	SCREW PAN (S/P WASHER) M4X10	
27	525907000	1	コードホルダ#9	CORD HOLDER #9	
28	SA3416101	1	イトチョウシバネLL	TENSION SPRING LL	
29	S48140002	1	ザガネ	WASHER	
30+	* P.68	1	テヨウシバネウエザガネ	WASHER	

T2. 付属装置関係(オプション部品) / Attachment set (Option parts)

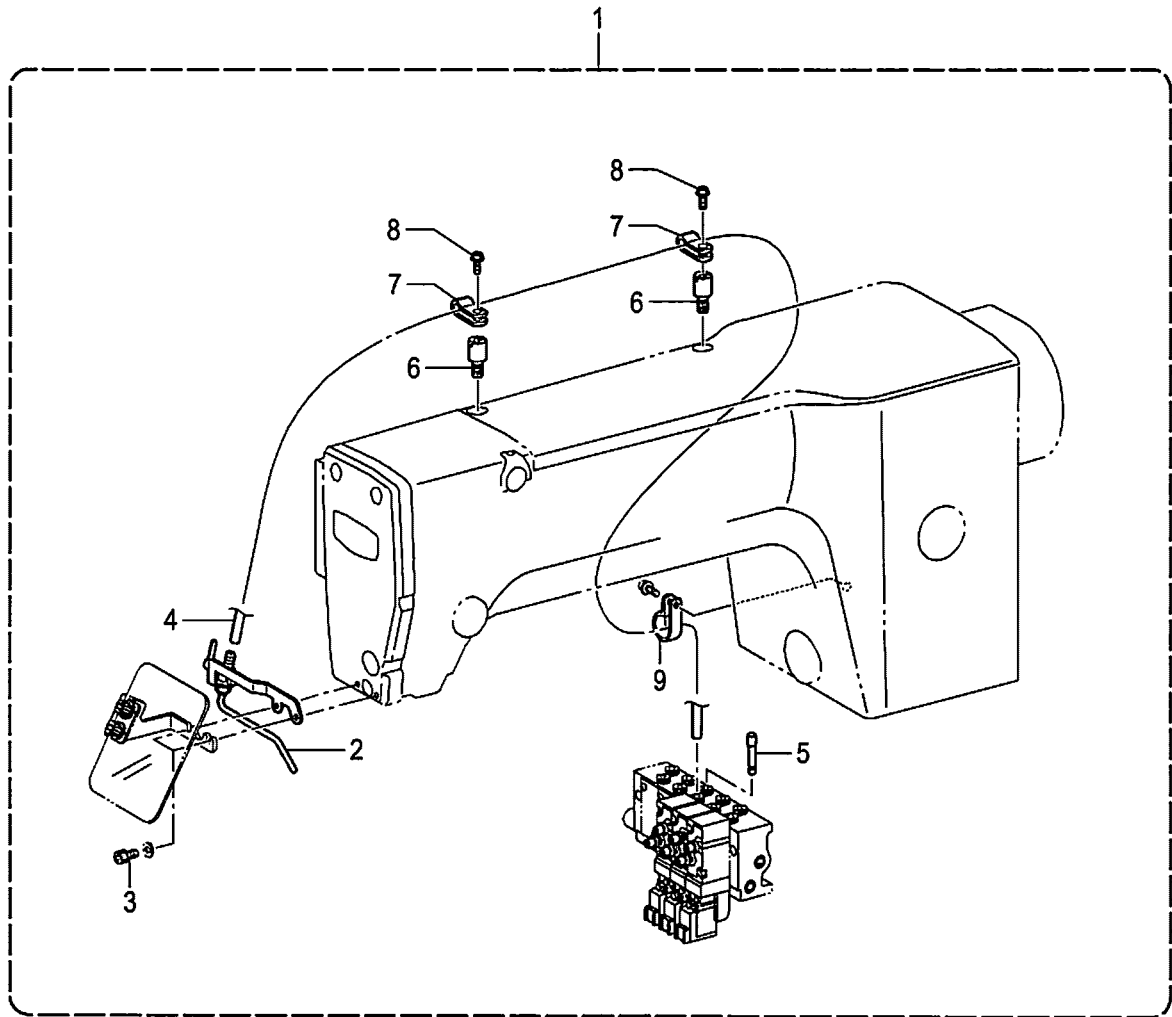

## T2. 付属装置関係 (オプション部品) / Attachment set (Option parts)

REF.NO	CODE	Q'TY	品名	NAME OF PARTS	RM
1	SA5559101	1	ニードルクーラーソウチセット	NEEDLE COOLER SET	
2	S18027201	1	ニードルブロワー	NEEDLE BLOWER	
3	018400836	2	アナボルト4X8	BOLT SOCKET M4X8	
4	S15031010	1	エアチューブ	AIR TUBE, 4X2.5	
5	S04897000	1	プラグ4	PLUG 4	
6	SA7155001	2	スペーサ	SPACER	
7	S10243000	2	ナイロンクランプNK-3N	CORD HOLDER, NK-3N	
8	0A5401006	2	+ナベザクミ4X10DB	SCREW PAN (S/P WASHER) M4X10	
9	525907000	1	コードホルダ#9	CORD HOLDER #9	

BAS-311H-940

T3. 付属装置関係(オプション部品) / Attachment set (Option parts)

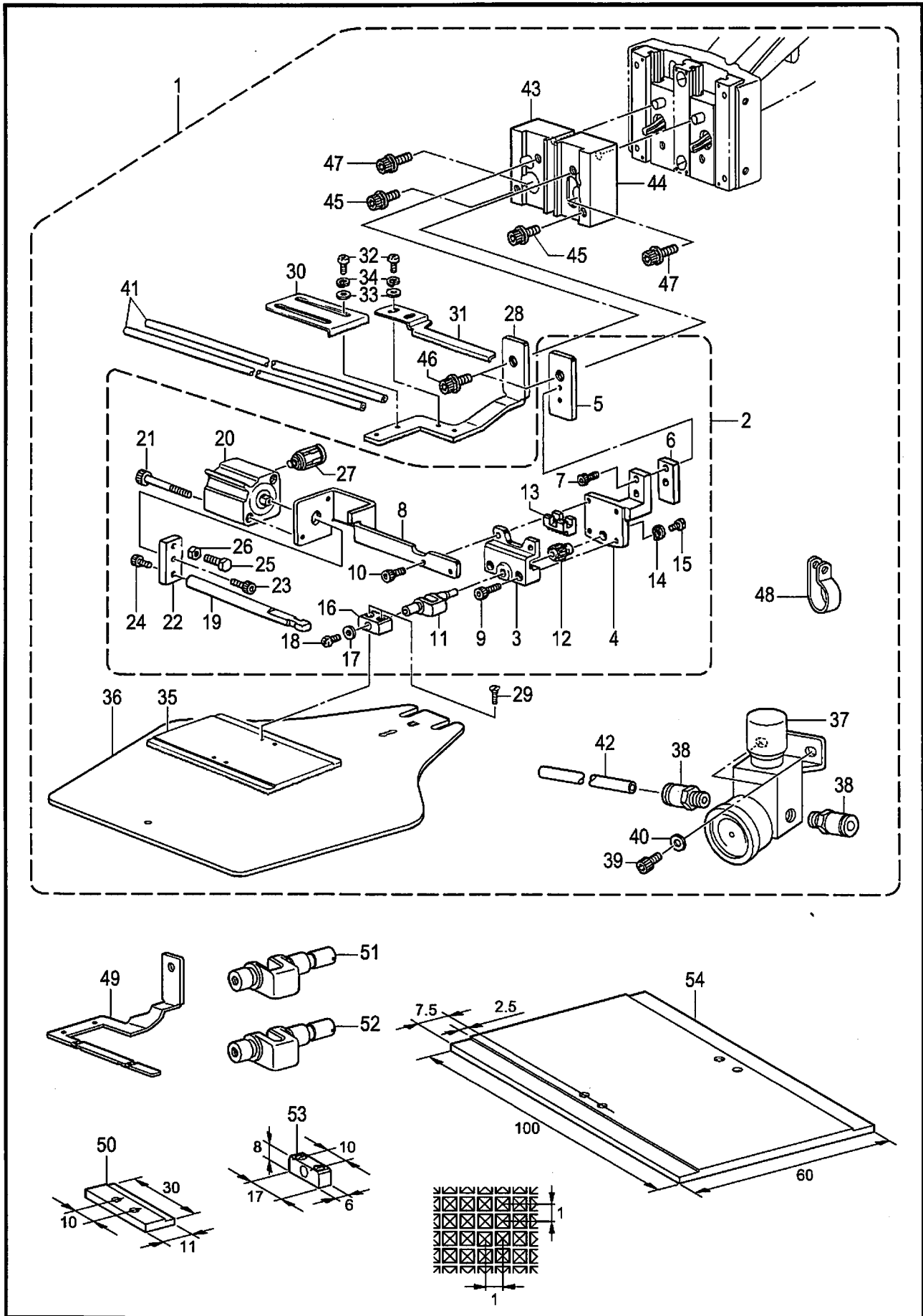

## T3. 付属装置関係 (オプション部品) / Attachment set (Option parts)

REF.NO	CODE	Q'TY	品名	NAME OF PARTS	RM
1	SA7189101	1	ネームツケハンテンスOUCHセツト	INNER CLAMPING DEVICE SET	
2	S12633309	1	オサエクランクLAクミ	WORK CLAMP CRANK ASSY LA	
3	S12634109	1	オサエクランクホルダA	WORK CLAMP CRANK HOLDER, A	
4	S12635009	1	オサエクランクホルダB	WORK CLAMP CRANK HOLDER, B	
5	S12636001	1	オサエクランクホルダC	WORK CLAMP CRANK HOLDER, C	
6	S12641009	1	クランクホルダカンザ	SPACER, CRANK HOLDER	
7	S59894001	2	アナボルト437-40X12	BOLT, SOCKET SM4.37-40X12	
8	SA6373001	1	ハンテンスリンダダイ	REVERSE CYLINDER BASE	
9	018301236	2	アナボルト3X12	BOLT SOCKET M3X12	
10	018301036	2	アナボルト3X10	BOLT SOCKET M3X10	
11	S05665001	1	オサエクランクLA	WORK CLAMP CRANK, LA	
12	154235001	1	ハンテングヤ	REVERSE GEAR	
13	154236001	1	ハンテラツク	REVERSE RACK	
14	145087001	1	ハンテングヤザガネ	WASHER	
15	149831101	1	アタマツキトメネジ3.18	SET SCREW, SM3.18	
16	154237101	1	オサエイタホルダL	WORK CLAMP PLATE HOLDER, L	
17	025350132	1	ヒラザガネシヨウ3.5	WASHER PLAIN S 3.5	
18	100242003	1	シメネジ3.57	SCREW, SM3.57-40X5	
19	S12637009	1	ハンテorroツド	REVERSE ROD	
20	SA6362001	1	ハンテンスリンダ	REVERSE CYLINDER	
21	S12642009	2	アナボルト3X35	BOLT SOCKET M3X35	
22	SA7193001	1	ハンテングツギテ	REVERSE SHAFT JOINT	
23	018400836	1	アナボルト4X8	BOLT SOCKET M4X8	
24	018300836	1	アナボルト3X8	BOLT SOCKET M3X8	
25	017501216	1	ボルト5X12	BOLT M5X12	
26	021500216	1	2シュナツト5	NUT 2 M5	
27	S18415101	2	ハーフユニオンQ4M5	HALF UNION: Q4M5	
28	S12643001	1	ソトオサエアシ312-1	OUTER WORK CLAMP, 312-1	
29	117291002	2	サラネジ3.18	SCREW, FLAT SM3.18	
30	154252001	1	イチギメイタル	POSITIONING PLATE, L	
31	154253001	1	イチギメイタル	POSITIONING PLATE, R	
32	062670512	4	ナベコ357-40X5	SCREW PAN SM3.57-40X5	
33	SB2456001	4	ヒラザガネダイ3.5	WASHER PLAIN 3.5	
34	028350242	4	バネザガネ2-3.5	WASHER SPRING 2-3.5	
35	154256101	1	オサエイタブランクA	WORK CLAMP PLATE BLANK, A	
36	SA7460001	1	オクリイタブランク311G	FEED PLATE BLANK 311G	
37	S12165000	1	レギュレータ-	REGULATOR	
38	S04905000	2	ハーフユニオン	HALF UNION	
39	018400636	2	アナボルト4X6	BOLT SOCKET M4X6	
40	SB3848001	2	ヒラザガネチュウ4	WASHER_PLAIN_M_4	
41	S03803000	2	ナイロンチューブ	AIR TUBE	
42	S28741000	1	エア-チューブ	AIR TUBE, 4 L=300	
43	SA6617001	1	オサエクランクスペーサL	WORK CLAMP CRANK SPACER L	
44	SA6616001	1	オサエクランクスペーサR	WORK CLAMP CRANK SPACER R	
45	S55484001	2	アナボルトザクミ5X10	BOLT SOCKET (S/P WASHER)M5X10	
46	S55484001	2	アナボルトザクミ5X10	BOLT SOCKET (S/P WASHER)M5X10	
47	S55485001	2	アナボルトザクミ5X12	BOLT SOCKET (S/P WASHER) M5X12	
48	552907000	1	コードホルダ#10	CORD HOLDER #10	
49	S12644001	1	ソトオサエアシ312-2	OUTER WORK CLAMP, 312-2	
50	S10542001	1	ナカオサエLL	INNER CLAMP, LL	
51	S04516001	1	オサエクランクSS	WORK CLAMP CRANK, SS	
52	154297001	1	オサエクランクS	WORK CLAMP CRANK, S	
53	154291101	1	オサエイタホルダS	WORK CLAMP PLATE HOLDER, S	
54	156492101	1	オサエイタブランク7.5-A	WORK CLAMP PLATE BLANK7.5-A	

T4. 付属装置関係(オプション部品) / Attachment set (Option parts)

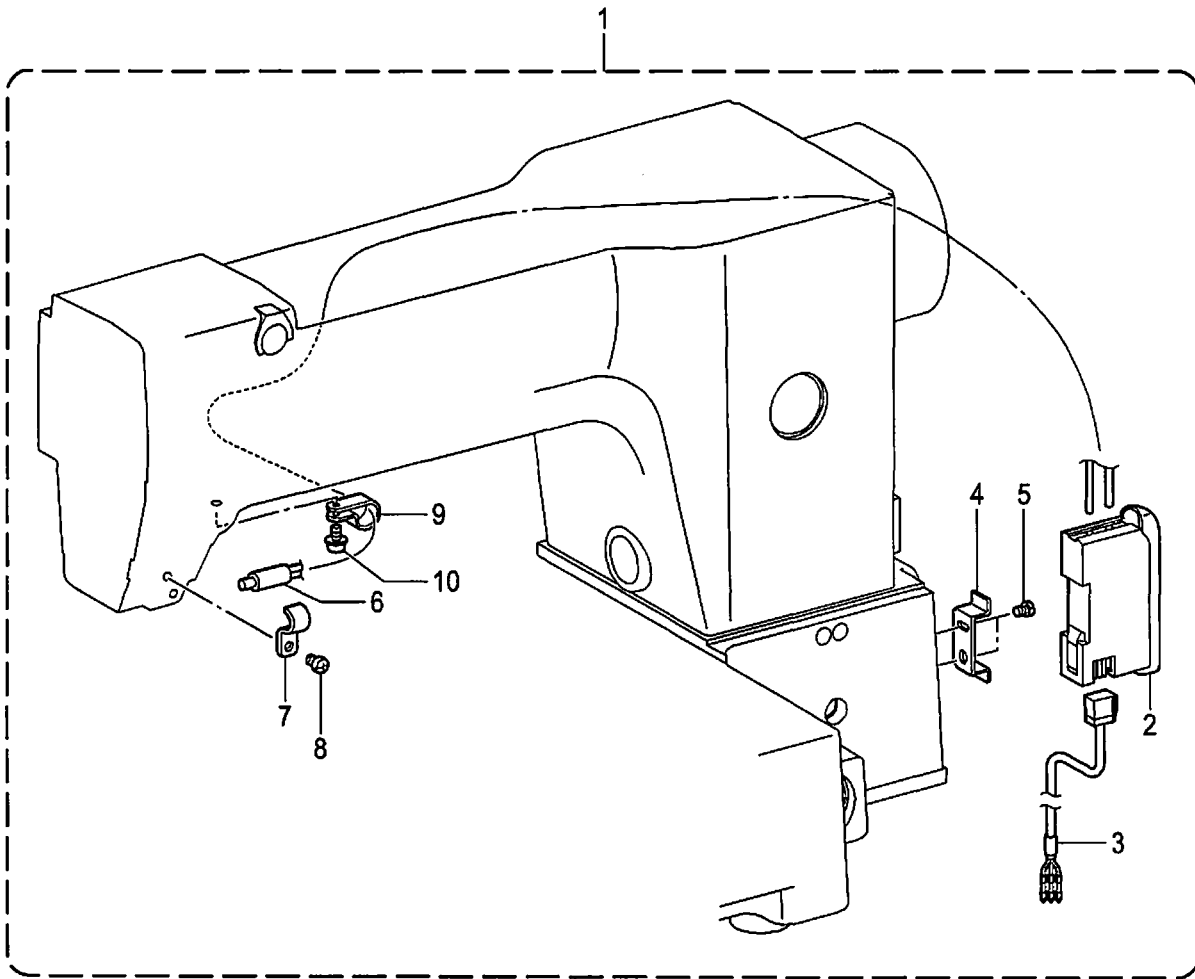



T4. 付属装置関係 (オプション部品) / Attachment set (Option parts)

REF.NO	CODE	Q'TY	品名	NAME OF PARTS	RM
1	SA5193101	1	イトキレカンチソウチクミF	TR-BREAKAGE DETECTOR SET F	
2	SA4816001	1	ファイバアンプFX311	FIBER AMP FX311	
3	SA4817001	1	アンプケーブルクミ	AMP CABLE ASSY	
4	SA4818001	1	アンプトリツケDINカナグ	DIN METAL FITTING	
5	062300616	2	ナベコ3X6	SCREW PAN M3X6	
6	SA4819001	1	ファイバFDFM2	FIBER FDFM2	
7	SA5194001	1	センサトリツケイタ	SENSOR SETTING PLATE	
8	062500616	1	ナベコ5X6	SCREW PAN M5X6	
9	625010000	1	ナイロンクランプNK-2N	NYLON CLAMP NK-2N	
10	0A5401006	1	+ナベザクミ4X10DB	SCREW PAN (S/P WASHER) M4X10	

BAS-311H-940

Z. 付属品関係 / Accessories

<オプション部品 / Option parts >

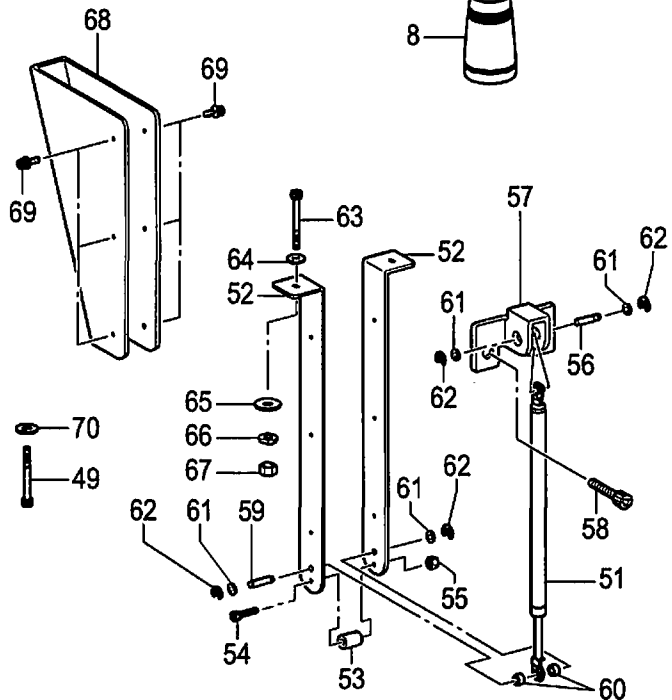
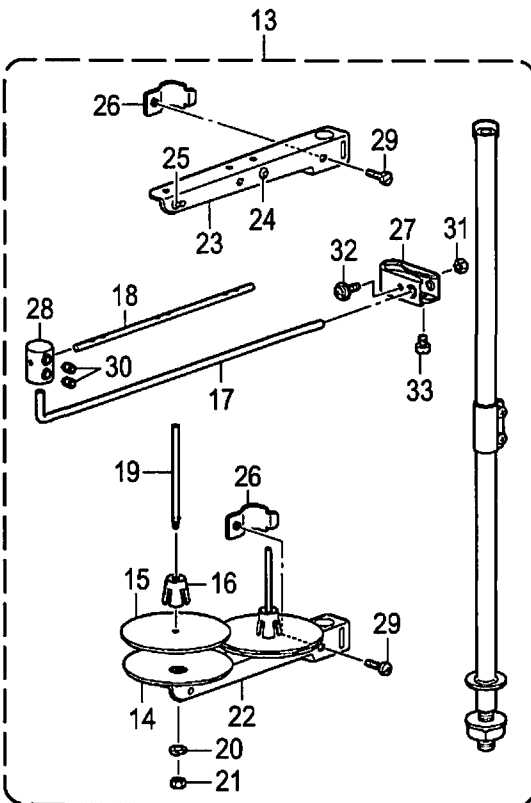
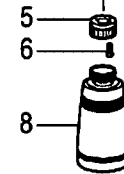
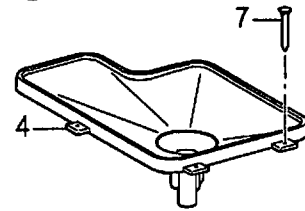
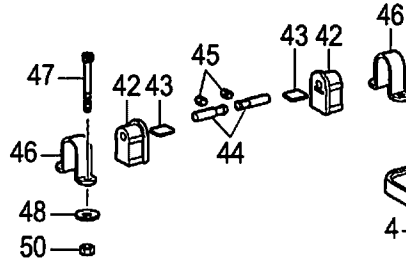
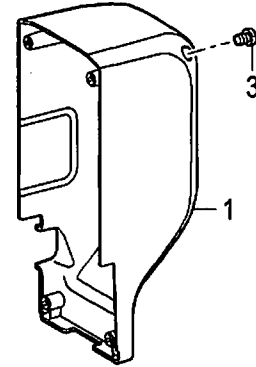
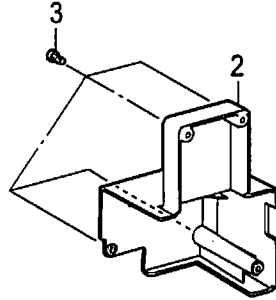
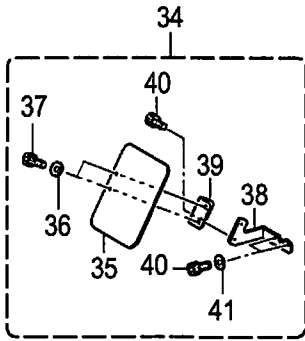
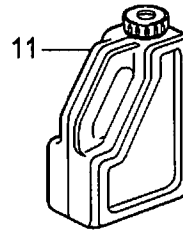
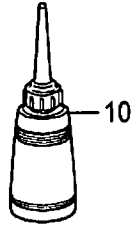
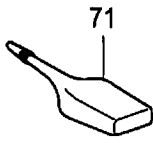

BAS-311H-910

## Z. 付属品関係 / Accessories

REF.NO	CODE	Q'TY	品名	NAME OF PARTS	RM
1	SB4412001	1	リアカバー	REAR COVER	
2	SB4403001	1	サイドカバー	SIDE COVER	
3	062501216	8	ナベコ5X12	SCREW PAN M5X12	
4	SB4383001	1	オイルパン	OIL PAN	
5	154467001	1	ハイユキヤツブ	DUST OILER	
6	037301215	2	Vナベタツピン3X12	TAPPING SCREW PAN V M3X12	
7	109714000	6	クギ	NAIL	
8	114486002	1	ポリオイラータイ	OILER	
9+	* P.67	1	ボビン	BOBBIN	
10	114483002	1	ポリオイラークミ	OILER ASSY	
11	SB1543002	1	オイルタンククミ	OIL TANK ASSY	
12	SB1505001	1	オイルケイコクラベル	OIL WARNING LABEL	
13	S40574409	1	イトタテダイクミ2DTHF	COTTON STAND ASSY 2DTHF	
14	S51283001	2	ウケザラ	SPOOL STAND BASE	
15	150182000	2	スプールマット	SPOOL MAT	
16	S51282101	2	スプールクッション	SPOOL CUSHION	
17	S04109001	1	イトアンナイササエボウ	THREAD GUIDE SUPPORT BAR	
18	142997001	1	イトアンナイ3	THREAD GUIDE, 3	
19	150179002	2	スプールジクB	SPOOL SHAFT B	
20	028050243	2	バネザガネ2-5	WASHER SPRING 2-5	
21	021500203	2	2シュナツト5	NUT, 2 M5	
22	SA6607001	1	スプールホルダー-2	SPOOL HOLDER 2	
23	SA6607001	1	スプールホルダー-2	SPOOL HOLDER 2	
24	150183000	2	イトカケハンガーダイ	THREAD HANGER BASE	
25	142990001	2	スレツドブツシュ	THREAD BUSH	
26	SA6609001	2	スプールホルダー-ササエ	SPOOL HOLDER SUPPORTER	
27	SA6615001	1	イトアンナイホルダー	THREAD GUIDE HOLDER	
28	138843201	1	ササエボウツギテ	JOINT	
29	062061603	2	ナベコ6X16	SCREW PAN M6X16	
30	014060632	2	アナクボミ6X6	SET SCREW SOCKET (CP) M6X6	
31	021500203	1	2シュナツト5	NUT, 2 M5	
32	S37037001	1	ナベコヒラザ5X32	SCREW PAN (S/P WASHER) M5X32	
33	062061003	1	ナベコ6X10	SCREW PAN M6X10	
34	SB0557101	1	アイガードセットE	EYE GUARD SET E	
35	S44485101	1	アイガード	EYE GUARD	
36	026030233	2	ヒラザガネミガキ3	WASHER PLAIN M 3	
37	018300636	2	アナボルト3X6	BOLT SOCKET M3X6	
38	SB0559101	1	アイガードホルダー-A	EYE GUARD HOLDER A	
39	SB0556001	1	アイガードホルダー-B	EYE GUARD HOLDER B	
40	018400836	3	アナボルト4X8	BOLT SOCKET M4X8	
41	026040136	2	ヒラザガネコガタ	WASHER PLAIN S 4	
42	SA3395001	2	トウブヒンジゴム	RUBBER CUSHION	
43	SA3392001	2	スペーサ	SPACER	
44	SA3384101	2	トウブササエピン	PIN	
45	012060636	2	アナヒラ6X6	SET SCREW SOCKET (FT) M6X6	
46	SA3385001	2	トウブヒンジウケ	HINGE HOLDER	
47	018066036	4	アナボルト6X60	BOLT SOCKET M6X60	
48	213650001	4	ワ2.3X8.5X38ST	WASHER, 2.3X8.5X38ST	
49	018066036	2	アナボルト6X60	BOLT SOCKET M6X60	
50	021060106	4	1シュナツト6	NUT 1 M6	
51	SB0468001	1	ガススプリングクミ311G	SHOCK ABSORBER GAS ASSY 311G	
52	SA4846002	2	ガススプリングササエ	HOLDER ABSORBER	
53	SA5251001	1	スペーサ	SPACER	
54	018064031	1	アナボルト6X40	BOLT SOCKET M6X40	
55	021060106	1	1シュナツト6	NUT 1 M6	
56	SB4517001	1	ガススプリングジクU	SHAFT U	
57	SB4516001	1	ガススプリングトリツケイタ	ABSORBER SETTING PLATE	
58	S42446001	2	アナボルトザクミ6X14	BOLT SOCKET (S/P WASHER)M6X14	
59	S17974101	1	ガススプリングジクD	SHAFT D	
60	S17975200	2	GSジクカラ	SHAFT COLLAR, GAS	
61	SB2356001	4	ヒラザガネシヨウ8	WASHER PLAIN S 8	
62	048060342	4	トメワE6	RETAINING RING E6	

Z. 付属品関係 / Accessories

<オプション部品 / Option parts >

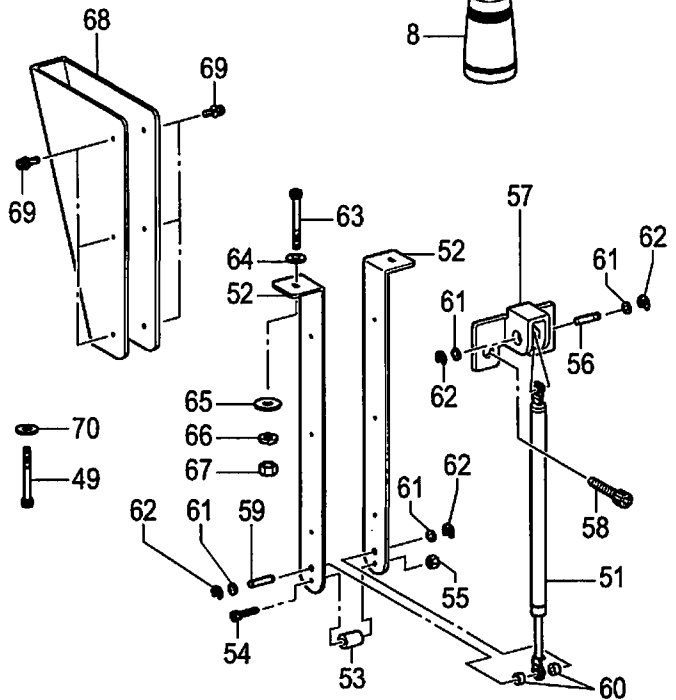
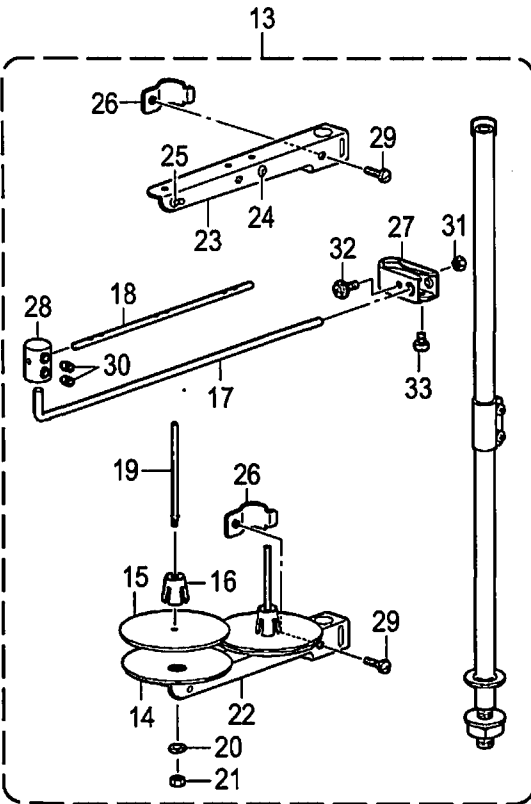
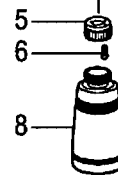
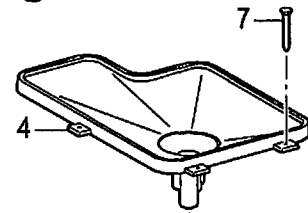
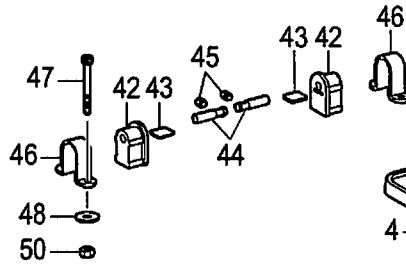
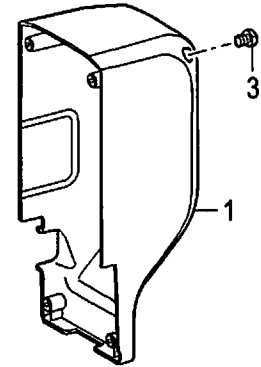
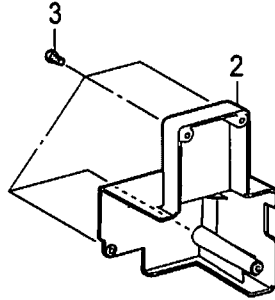
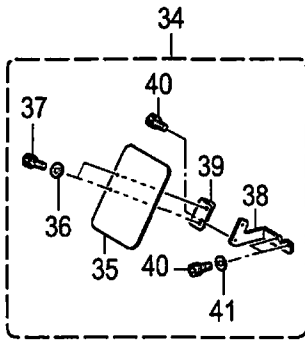
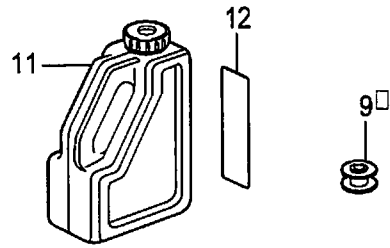
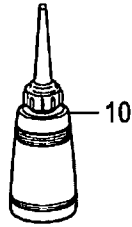
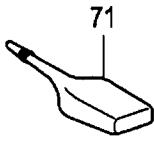







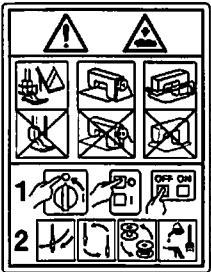

BAS-311H-910

## Z. 付属品関係 / Accessories

REF.NO	CODE	Q'TY	品名	NAME OF PARTS	RM
63	018066036	2	アナボルト6X60	BOLT SOCKET M6X60	
64	025060236	2	ヒラザガネチュウ6	WASHER PLAIN M 6	
65	213650001	2	ワ2.3X8.5X38ST	WASHER, 2.3X8.5X38ST	
66	028060246	2	バネザガネ2-6	WASHER SPRING 2-6	
67	021060106	2	1シュナット6	NUT 1 M6	
68	SA6261002	1	ガススプリングササエカバー	HOLDER ABSORBER COVER	
69	S55479001	6	アナボルトザクミ4X8	BOLT SOCKET (S/P WASHER) M4X8	
70	025060236	2	ヒラザガネチュウ6	WASHER PLAIN M6	
			<オプション部品>	<Option parts>	
71	S06706001	1	シリコンオイル	SILICONE OIL	











Wa. 警告ラベル / Warning labels

警告ラベル / Warning labels	品名 / Name of parts	Size(mm)	Code
	ラベル感電6ヶ国 Label electrical shock 36 X 150	36 X 150	SA9725-001
	ラベル感電 25 X 28 Label electrical shock 25 X 28	L=28.4	SA9914-001
	操作注意ラベル Label caution	56 X 43	SA9826-001
	ワーニングマーク Injury mark	L=16	SA9957-001
	ワーニングマーク Injury mark	L=25	SA9957-002
	アースマーク Label, grounding	φ 12	S37060-001
	PE マーク Label, PE	7.5 X 12.5	S37059-001
	マークチュウイ 30 X 40 Mark attention 30 X 40	30 X 40	SA4224-001

Wa. 警告ラベル / Warning labels







警告ラベル / Warning labels	品名 / Name of parts	Size(mm)	Code
<div data-bbox="339 244 531 1074" style="border: 1px solid black; padding: 5px;"> <p><b>brother</b>                      ミシン用潤滑油                      Lubricating Oil for Machining</p> <p><b>▲ 注意</b></p> <p>目に入ったり皮膚につくと、                      炎症を起こすことがある。                      保護めがね、手袋を使                      うこと。</p> <p>飲み込むと、                      下痢、嘔吐する。                      飲み込まないこと。</p> <p>●子供の手の届かない所に                      置いてください。</p> <p>●目に入った場合は、清潔な                      水で15分間洗浄し、医師の                      診察を受けてください。</p> <p>●皮膚に付けた場合は、水と                      石けんで十分に洗ってくだ                      さい。</p> <p>●飲み込んだ場合は、無理に                      吐かせずに、直ちに医師の                      診察を受けてください。</p> <p>第4項 第3石油類                      危険等級III 火気厳禁</p> <p><b>▲ CAUTION</b></p> <p>Lubricating oil                      may cause inflammation                      to eye and skin.                      Wear protective glasses                      and gloves.</p> <p>Swallowing oil                      can cause diarrhoea                      and vomiting.                      Do not swallow.</p> <p>Keep away from children.  <b>FIRST AID</b>                      Eye contact:                      -Rinse with plenty of cold water.                      -Seek medical help.</p> <p>Skin contact:                      -Wash with soap and water.                      If swallowed:                      -Seek medical help immediately.                      -Do not induce vomiting.</p> </div>	<p>オイル警告ラベル                      Oil warning label</p>	<p>148 X 34</p>	<p>SB1505-001</p>

Sp. 仕様別部品一覧表 / Different parts list

品名 Part name	仕様 Spec.	中厚物 Medium-weight materials	厚物 Heavy-weight materials	シートベルト Seatbelt
(J-57) 針穴板 Needle hole plate 		(φ2.2) SA5221-001	(φ2.4) SA3336-101	(φ3.0) SA5222-101
(J-54) 固定刃 Fixed knife 		SA7944-101 < FL >		SB0623-001 < FLL >
(E-38) ボビンケース組 Bobbin case assy 		S59221-301 < LC >		S59222-301 < LD >
(E-39) ボビンケース 調子ばね Tension spring 		S48664-001 < AN >		S16075-101 < B >
(E-40) ボビンケース ばねねじ Screw 		S16492-101		
(E-41) 空転防止ばね Anti-spin spring 		S15667-001		
(E-42) (Z-9) ボビン Bobbin 		S44633-001 < LAN >		S15666-001 < LB >
(E-34) ドライバー Driver 		SA6448-301 < E >		S55215-101 < HR >
(E-37) 中がま箱組 Shuttle hook assy, w/box 		SA2173-301 < LF >	SA8197-101 < LH >	SA8197-101 < LH >
(E-36) 大がま Shuttle race base 		152682-201 < A >	152686-201 < B >	152686-201 < B >



Sp. 仕様別部品一覧表 / Different parts list

仕様 Spec.	中厚物 Medium-weight materials	厚物 Heavy-weight materials	シートベルト Seatbelt
品名 Part name (G-25) 糸調子ばね Tension spring 	104525-101	107606-101	107606-101
(G-7) 糸取りばね Thread take-up spring 	SA9058-001	144588-401	144588-401
(G-23) 副調子ばね Sub tension spring 	SA4146-101		SA3416-101
(T1-30) 調子ばね上ザガネ Washer 	—		S20681-000
(G-20) 針棒糸案内 Needle bar thread guide  A  B	SA3257-101 < A >		SA4815-201 < B >
(D1-57) 押え足 Presser foot 	S42843-001 < A >		S42844-001 < B >

Ga. ゲージ部品一覧表 / Gauge parts list

押え足 / Presser foot			
A / S42843-001 *	B / S42844-001	C / S42845-001	D / S42846-001
E / S42847-001	F / 157237-001	G / 158592-001	J / S42848-001
A-CUT / S40214-001	B-L / S49448-001	XA / S42849-101	H / SA4811-001

針穴板 / Needle hole plate			
2.4 C0.4 / SA3336-101 *	2.2 / SA5221-001 *	3.0 C1.5 / SA5222-101 *	1.6 / SA7191-001

\*印の部品は、標準部品です。

The \* symbol is for Standard parts.

CODE	REF.NO	Page	CODE	REF.NO	Page	CODE	REF.NO	Page	CODE	REF.NO	Page
004300513	A -22	2	016061031	D2 -36	20	021060306	J -23	32	060400516	K -21	36
012060536	B -37	4		D3 -14	22	021080206	M1 -12	40		L -17	38
	C3 -11	10	017061213	D1 -12	18	021300103	A -26	2	062060816	F -30	26
	C3 -23	10	017061612	D1 -44	18	021400106	C4 -54	12	062061003	Z -33	62
	C4 -17	12	017065002	D1 -45	18		C5 -48	14	062061016	A -19	2
	C4 -33	12	017081606	T1 -22	54	021400216	C1 -40	6		F -4	26
	C5 -23	14	017400802	J -5	32		C2 -4	8		H -37	30
	D1 -55	18		L -2	38		C4 -26	12	062061603	Z -29	62
	E -6	24	017401415	L -5	38	021400306	G -18	28	062300416	C1 -49	6
012060636	B -24	4	017501216	T3 -25	58		L -6	38		D1 -20	18
	C1 -18	6	017501616	C4 -49	12	021500203	Z -21	62		J -55	34
	C1 -22	6		C5 -41	14		Z -31	62		J -64	34
	C1 -33	6	018061236	D2 -58	20	021500216	C4 -45	12	062300506	A -25	2
	C4 -4	12		D3 -27	22		C5 -34	14	062300616	E -20	24
	C4 -13	12	018061636	J -43	32		C5 -39	14		K -7	36
	C4 -22	12	018063036	C1 -19	6		T3 -26	58		T4 -5	60
	C4 -29	12	018064031	Z -54	62	025040136	A -32	2	062300816	P -6	46
	C5 -4	14	018066036	Z -47	62	025040236	C6 -12	16	062350616	H -8	30
	C5 -6	14		Z -49	62	025060236	Z -64	64	062400416	D2 -6	20
	C5 -19	14		Z -63	64		Z -70	64	062400616	C3 -5	10
	D1 -14	18	018300636	Z -37	62	025080336	M1 -10	40		D1 -6	18
	D1 -24	18	018300836	T3 -24	58	025350132	T3 -17	58		D2 -29	20
	D1 -30	18	018301036	T3 -10	58	026030233	Z -36	62		D2 -54	20
	D1 -36	18	018301236	T3 -9	58	026040136	F -33	26		D2 -56	20
	D2 -11	20	018301436	C6 -3	16		Z -41	62		D3 -11	22
	D2 -14	20	018302036	T1 -11	54	026040236	J -7	32		D3 -26	22
	D2 -25	20	018400636	D2 -39	20		L -4	38		F -6	26
	D2 -33	20		D3 -17	22	028030246	J -62	34		F -13	26
	D2 -37	20		F -11	26	028040246	C1 -39	6		F -32	26
	D2 -41	20		T3 -39	58		C5 -16	14	062400816	B -22	4
	D2 -57	20	018400836	C3 -21	10		J -6	32		B -33	4
	D3 -7	22		C5 -15	14		L -3	38		C1 -13	6
	D3 -15	22		D1 -48	18	028050243	Z -20	62	062401016	A -7	2
	D3 -19	22		D2 -3	20	028050246	C4 -37	12		A -31	2
	D3 -32	22		K -9	36		C4 -51	12	062401216	C1 -50	6
	D3 -33	22		T2 -3	56		C5 -43	14	062500616	G -5	28
	E -9	24		T3 -23	58		N -11	44		H -30	30
	E -12	24		Z -40	62	028060246	Z -66	64		T4 -8	60
	E -33	24	018401036	C3 -9	10	028080246	M1 -11	40	062500816	L -10	38
	G -27	28		C3 -14	10	028350242	T3 -34	58	062501216	A -28	2
	J -37	32		C3 -26	10	032422003	N -19	44		Z -3	62
	Z -45	62		D2 -23	20	037301215	Z -6	62	062670412	G -30	28
012400436	D1 -25	18		D3 -5	22	047402042	B -45	4	062670512	T3 -32	58
	D1 -31	18		F -48	26	048030342	K -19	36	070696800	D2 -44	20
	H -17	30	018401236	H -13	30	048040142	C4 -9	12		D2 -49	20
	H -24	30	018401636	B -27	4	048040342	J -20	32		D3 -22	22
	J -9	32	018500836	C4 -35	12		K -12	36	081003670	E -48	24
012400636	C1 -4	6	018501036	C1 -3	6		L -13	38	085311016	Q -11	48
012500536	B -21	4		C3 -15	10	048050142	C5 -8	14	0A4300806	K -26	36
	B -34	4		C3 -27	10	048050342	H -10	30	0A4400806	Q -8	48
	B -35	4		D2 -21	20		H -19	30		Q -9	48
	D2 -46	20		D3 -3	22	048060142	C5 -11	14	0A5301605	P -8	46
	D2 -51	20	018501232	E -35	24	048060342	Z -62	62	0A5401006	F -38	26
	D3 -24	22	018501636	B -3	4	048080142	C4 -14	12		F -44	26
	E -44	24		B -36	4		C4 -30	12		F -45	26
	H -3	30	018503036	N -12	44		C5 -20	14		F -50	26
	H -36	30	021060106	D1 -10	18		D1 -29	18		N -22	44
	J -42	32		D1 -46	18	048080342	D2 -13	20		P -4	46
012501031	C4 -44	12		J -31	32	048100142	C1 -26	6		P -13	46
	C5 -33	14		Z -50	62		C4 -6	12		T1 -26	54
	C5 -38	14		Z -55	62		D2 -28	20		T2 -8	56
014060632	Z -30	62		Z -67	64		D3 -10	22		T4 -10	60
016061031	D2 -32	20	021060306	D1 -41	18	048280142	B -43	4	0B0452006	Q -13	48

## 索引 / Index

CODE	REF.NO	Page	CODE	REF.NO	Page	CODE	REF.NO	Page	CODE	REF.NO	Page
100136001	G -22	28	150182000	Z -15	62	J00353001	M1 -6	40	S23651001	B -8	4
100242003	T3 -18	58	150183000	Z -24	62	J04417001	M1 -3	40		B -14	4
100360003	J -58	34	151439102	D1 -59	18	S00470000	P -15	46		B -17	4
100401022	H -33	30	152682201	Sp	67	S00480000	T1 -25	54		B -39	4
100402004	G -12	28	152684101	E -18	24	S00705001	J -52	34		D1 -5	18
100645004	C5 -17	14	152686201	Sp	67	S02429201	E -15	24		D1 -15	18
102630021	D2 -9	20	152744001	D2 -8	20	S02652021	J -11	32		E -8	24
102707002	L -7	38	152881101	G -26	28	S03677001	K -23	36		J -2	32
104449001	A -4	2	152883000	G -28	28	S03803000	T3 -41	58		J -25	32
	A -36	2	152884001	G -29	28	S03816001	M1 -17	40	S23849101	C5 -25	14
104450101	A -39	2	152936001	H -6	30		M2 -3	42	S25235001	B -15	4
104525101	Sp	68	152937001	H -7	30	S04109001	Z -17	62	S25279101	K -14	36
104567101	F -19	26	153274001	N -9	44	S04516001	T3 -51	58	S25310101	D1 -37	18
104821001	A -5	2	154235001	T3 -12	58	S04897000	T2 -5	56		J -59	34
	D3 -29	22	154236001	T3 -13	58	S04905000	T3 -38	58	S25454021	K -13	36
107606101	Sp	68	154237101	T3 -16	58	S05665001	T3 -11	58	S25456021	K -4	36
108802001	E -46	24	154252001	T3 -30	58	S06706001	Z -71	64	S25475101	J -30	32
109714000	Z -7	62	154253001	T3 -31	58	S07350002	A -11	2	S28741000	T3 -42	58
109763022	D2 -45	20	154256101	T3 -35	58	S07459100	F -16	26	S31032002	G -9	28
	D2 -50	20	154291101	T3 -53	58	S08003000	F -53	26		H -34	30
	D3 -23	22	154297001	T3 -52	58		F -58	26	S32465101	J -22	32
110367001	B -18	4	154467001	Z -5	62	S09043000	F -24	26		J -34	32
	C4 -15	12	154596000	J -29	32	S09228000	N -6	44	S34533001	T1 -13	54
	C4 -31	12	154599000	J -10	32	S10112101	D1 -52	18	S34534101	T1 -14	54
	C5 -21	14		L -8	38	S10243000	T2 -7	56	S34706000	T1 -10	54
110735022	K -18	36	155510001	T1 -15	54	S10268001	H -27	30	S35079000	D2 -35	20
111466121	D1 -56	18	155559021	H -9	30	S10438001	H -18	30	S35183000	C4 -3	12
114483002	Z -10	62		H -25	30	S10470201	K -20	36		C5 -3	14
114486002	Z -8	62	156492101	T3 -54	58	S10542001	T3 -50	58	S36475000	A -12	2
117291002	T3 -29	58	157237001	Ga	69	S12150000	T1 -12	54	S37037001	Z -32	62
117608001	A -2	2	158592001	Ga	69	S12165000	T3 -37	58	S37059001	M1 -8	40
118208001	D2 -15	20	159150000	A -34	2	S12441001	G -24	27		Wa	65
118550001	D3 -30	22	159163000	A -33	2		H -35	30	S37060001	A -41	2
120265002	A -10	2		D3 -28	22	S12633309	T3 -2	58		M1 -7	40
120448001	H -23	30	159805001	G -10	28	S12634109	T3 -3	58		Wa	65
138843201	Z -28	62	200190001	M1 -18	40	S12635009	T3 -4	58	S38265000	F -51	26
141362001	D1 -34	18		M2 -4	42	S12636001	T3 -5	58	S38266000	F -42	26
142211001	B -25	4		Q -14	48	S12637009	T3 -19	58	S38713100	B -32	4
142274101	F -52	26	213650001	Z -48	62	S12641009	T3 -6	58	S39116100	N -3	44
142990001	Z -25	62		Z -65	64	S12642009	T3 -21	58		T1 -3	54
142997001	Z -18	62	218859001	P -16	46	S12643001	T3 -28	58		T1 -7	54
144458001	B -29	4	220681001	Q -10	48	S12644001	T3 -49	58	S40214001	Ga	69
144504001	T1 -20	54	228475000	N -23	44	S12699000	G -14	28	S40574409	Z -13	62
144588401	Sp	68	231071001	J -26	32	S13399001	D1 -58	18	S41205001	K -3	36
145087001	T3 -14	58	402887001	E -19	24	S15031010	T1 -23	54	S41206001	K -2	36
145446001	G -11	28	525567000	F -37	26		T2 -4	56	S42446001	A -16	2
	G -16	28		P -1	46	S15666001	Sp	67		C1 -31	6
145446002	H -32	30	525664000	F -39	26	S15667001	Sp	67		C2 -10	8
145465001	B -23	4		N -21	44	S16075101	Sp	67		C3 -17	10
145547021	F -31	26	525907000	T1 -27	54	S16492101	Sp	67		Z -58	62
146058001	T1 -18	54		T2 -9	56	S17974101	Z -59	62	S42843001	Sp	68
146059001	T1 -17	54	552907000	T3 -48	58	S17975200	Z -60	62		Ga	69
146060000	T1 -16	54	625010000	T4 -9	60	S18027201	T2 -2	56	S42844001	Sp	68
146206009	T1 -19	54	BMP3010-0000000-2ST1			S18415101	T3 -27	58		Ga	69
146288021	K -22	36		M2 -5+	42	S20164001	A -37	2	S42845001	Ga	69
148847001	N -20	44	BMP3010-0000000-3ST4			S20356001	D2 -12	20	S42846001	Ga	69
149097000	K -16	36		M2 -6+	42		D2 -52	20	S42847001	Ga	69
149287000	P -3	46	BMP3010-0000000-4ST4			S20681000	Sp	68	S42848001	Ga	69
149547000	F -36	26		M2 -6+	42	S23337001	A -35	2	S42849101	Ga	69
	P -2	46	BMP3010-0000001-3S00			S23418001	C6 -9	16	S44010001	A -38	2
149796001	N -24	44		M2 -2+	42		C6 -11	16	S44485101	Z -35	62
149831101	T3 -15	58	BMP3010-0000001-3ST4			S23418002	H -15	30	S44633001	Sp	67
150179002	Z -19	62		M2 -6+	42	S23651001	B -11	4	S46903001	J -19	32

CODE	REF.NO	Page	CODE	REF.NO	Page	CODE	REF.NO	Page	CODE	REF.NO	Page
S47307001	E -32	24	SA3242001	E -29	24	SA4175001	B -4	4	SA4744001	D2 -26	20
S48140002	T1 -29	54	SA3244001	F -1	26	SA4177001	B -10	4		D3 -8	22
S48189000	F -26	26	SA3246001	F -27	26	SA4178001	B -13	4	SA4745001	D2 -31	20
S48664001	Sp	67	SA3250001	G -1	28	SA4179001	B -6	4		D3 -13	22
S49448001	Ga	69	SA3254001	G -6	28	SA4180001	B -7	4	SA4746001	D2 -34	20
S49957000	F -34	26	SA3255001	G -8	28	SA4197101	C3 -22	10	SA4747001	D2 -38	20
S49982000	F -25	26	SA3256001	G -15	28	SA4199001	E -16	24		D3 -16	22
S49992000	F -20	26	SA3257101	Sp	68	SA4224001	C3 -16	10	SA4748101	D2 -40	20
S50359001	F -49	26	SA3258001	G -21	28		D2 -59	20		D3 -18	22
S50547000	F -61	26	SA3264101	A -23	2		D3 -34	22	SA4750001	D2 -47	20
S50557000	E -25	24	SA3274101	E -31	24		Wa	65	SA4752001	D2 -53	20
S51282101	Z -16	62	SA3280001	F -28	26	SA4302001	D1 -9	18	SA4753001	D2 -55	20
S51283001	Z -14	62	SA3283101	E -43	24	SA4333001	G -2	28		D3 -25	22
S53982000	T1 -4	54	SA3290001	H -2	30	SA4354001	J -47	32	SA4757101	D3 -31	22
S55215101	Sp	67	SA3291001	H -4	30	SA4518001	J -50	34	SA4759001	D1 -1	18
S55479001	C6 -6	16	SA3293001	H -11	30	SA4519001	J -51	34	SA4760001	D1 -2	18
	Z -69	64	SA3294001	H -14	30	SA4545001	J -36	32	SA4761001	D1 -7	18
S55482001	C4 -39	12	SA3295001	H -16	30	SA4574001	S -8	52	SA4762001	D1 -8	18
	C5 -27	14	SA3296001	H -21	30	SA4588001	J -41	32	SA4763001	D1 -3	18
S55484001	C2 -9	8	SA3297001	H -22	30	SA4594001	A -1	2	SA4764001	D1 -11	18
	C3 -2	10	SA3298001	H -28	30	SA4596001	A -3	2	SA4765001	D1 -13	18
	J -13	32	SA3299001	H -29	30	SA4600002	A -17	2	SA4766001	D1 -16	18
	T3 -45	58	SA3306001	A -9	2	SA4601001	A -18	2	SA4767001	D1 -17	18
	T3 -46	58		J -15	32	SA4603102	A -20	2	SA4768001	D1 -18	18
S55485001	C3 -28	10	SA3307001	J -8	32	SA4604101	A -8	2	SA4769101	D1 -19	18
	C4 -43	12	SA3309201	J -16	32	SA4605001	A -15	2	SA4770001	D1 -21	18
	C4 -52	12	SA3310001	J -17	32	SA4606201	B -1	4	SA4771001	D1 -27	18
	C5 -32	14	SA3311001	J -18	32	SA4608101	B -12	4	SA4772001	D1 -22	18
	C5 -37	14	SA3312201	J -27	32	SA4609101	B -16	4	SA4773001	D1 -23	18
	C5 -46	14	SA3313101	J -28	32	SA4622001	B -28	4	SA4775101	D1 -38	18
	K -25	36	SA3321001	J -39	32	SA4647001	C1 -15	6	SA4777001	D1 -26	18
	T3 -47	58	SA3334001	J -53	34		C1 -23	6	SA4778001	D1 -47	18
S59221301	Sp	67	SA3336101	Sp	67		D2 -27	20	SA4779101	D1 -32	18
S59222301	Sp	67		Ga	69		D3 -9	22	SA4780001	D1 -35	18
S59886001	E -22	24	SA3347001	L -12	38	SA4666001	B -30	4	SA4781001	D1 -33	18
S59894001	T3 -7	58	SA3348001	L -15	38	SA4676201	C2 -5	8	SA4782001	E -4	24
SA1174002	D1 -49	18	SA3384101	Z -44	62	SA4677101	C2 -2	8	SA4783101	E -10	24
SA1175002	D1 -50	18	SA3385001	Z -46	62	SA4687101	C4 -5	12	SA4785101	F -2	26
SA1394101	F -40	26	SA3392001	Z -43	62	SA4688001	C4 -7	12	SA4786101	F -8	26
SA1984001	H -12	30	SA3395001	Z -42	62	SA4689001	C4 -8	12	SA4787001	F -5	26
SA1988001	H -26	30	SA3416101	T1 -28	54	SA4692001	C4 -12	12	SA4788001	F -12	26
SA2161001	D1 -28	18		Sp	68		C4 -28	12	SA4789101	F -29	26
SA2173301	Sp	67	SA3441001	D3 -21	22		C5 -18	14	SA4791101	F -35	26
SA2195001	D1 -54	18	SA3441101	D2 -43	20	SA4693001	C4 -19	12	SA4796001	H -20	30
SA2287001	K -15	36		D2 -48	20	SA4706101	C4 -41	12	SA4797101	B -38	4
SA2864001	F -22	26	SA3499001	B -2	4		C5 -30	14	SA4798001	J -3	32
SA2929001	F -43	26	SA3503201	F -9	26	SA4709001	C4 -46	12	SA4799001	J -14	32
SA2958001	B -20	4	SA3504201	F -10	26		C5 -35	14	SA4806101	K -6	36
SA2972001	C1 -20	6	SA3528001	B -26	4		C5 -40	14	SA4811001	Ga	69
SA3206001	B -5	4	SA3538001	C1 -37	6	SA4712001	C5 -28	14	SA4815201	Sp	68
	B -9	4		C1 -52	6	SA4714001	C5 -29	14	SA4816001	T4 -2	60
SA3224001	B -31	4		C2 -12	8	SA4717001	C5 -5	14	SA4817001	T4 -3	60
SA3226001	E -1	24		J -60	34	SA4719001	C5 -7	14	SA4818001	T4 -4	60
SA3227001	D1 -42	18	SA3707101	C3 -10	10	SA4720001	C5 -9	14	SA4819001	T4 -6	60
	E -2	24	SA4025001	F -21	26	SA4721001	C5 -10	14	SA4837101	Q -6	48
SA3228101	E -3	24	SA4028001	F -60	26	SA4736001	D2 -7	20	SA4841101	Q -7	48
SA3231001	C4 -16	12	SA4131001	J -1	32	SA4737001	D2 -10	20	SA4846002	Z -52	62
	C4 -32	12	SA4143001	G -13	28	SA4738001	D2 -16	20	SA4853001	D1 -39	18
	C5 -22	14	SA4146101	Sp	68	SA4739001	D2 -18	20	SA4863001	C5 -24	14
	E -5	24	SA4171001	H -5	30	SA4741301	D2 -19	20	SA4864001	C4 -38	12
SA3233101	E -7	24	SA4172001	B -4	4		D3 -1	22		C5 -26	14
SA3238301	E -47	24	SA4173001	B -4	4	SA4743001	D2 -24	20	SA5135101	J -4	32
SA3241001	E -17	24	SA4174001	B -4	4		D3 -6	22	SA5164101	S -1	52

## 索引 / Index

CODE	REF.NO	Page	CODE	REF.NO	Page	CODE	REF.NO	Page	CODE	REF.NO	Page
SA5165001	S - 2	52	SA6599001	C6 - 14	16	SA9957002	A - 43	2	SB4277001	D3 - 4	22
SA5166001	S - 3	52	SA6600001	C6 - 15	16		Wa	65	SB4281001	C1 - 29	6
SA5167001	S - 7	52	SA6603001	C6 - 10	16	SB0445001	N - 8	44	SB4282001	C1 - 21	6
SA5172001	S - 5	52	SA6604001	C6 - 8	16	SB0468001	Z - 51	62	SB4296001	P - 7	46
SA5191001	N - 13	44	SA6607001	Z - 22	62	SB0553001	Q - 5	48	SB4297101	K - 1	36
SA5193101	T4 - 1	60		Z - 23	62	SB0556001	Z - 39	62	SB4334001	C3 - 8	10
SA5194001	T4 - 7	60	SA6609001	Z - 26	62	SB0557101	Z - 34	62	SB4335001	C1 - 32	6
SA5210001	P - 10	46	SA6615001	Z - 27	62	SB0559101	Z - 38	62	SB4337001	C1 - 30	6
SA5213001	K - 24	36	SA6616001	T3 - 44	58	SB0566001	Q - 12	48	SB4338001	C1 - 27	6
SA5219001	K - 17	36	SA6617001	T3 - 43	58	SB0623001	Sp	67	SB4339001	C1 - 16	6
SA5221001	Sp	67	SA7139001	C6 - 5	16	SB0705101	D2 - 17	20	SB4340001	C1 - 17	6
	Ga	69	SA7140001	C6 - 1	16	SB0713001	J - 65	34	SB4341001	C1 - 12	6
SA5222101	Sp	67	SA7141001	C6 - 7	16	SB0752101	Q - 1	48	SB4342001	C3 - 4	10
	Ga	69	SA7155001	T1 - 24	54	SB0787001	L - 16	38	SB4343001	C3 - 3	10
SA5251001	Z - 53	62		T2 - 6	56	SB0910201	B - 47	4	SB4344101	C1 - 1	6
SA5281201	N - 1	44	SA7166101	T1 - 5	54	SB1038001	B - 42	4	SB4346001	C3 - 1	10
SA5282001	N - 5	44	SA7167101	T1 - 8	54	SB1039001	B - 41	4	SB4351001	C1 - 8	6
SA5283001	N - 4	44	SA7171001	T1 - 6	54	SB1040001	B - 48	4	SB4356001	C1 - 36	6
SA5286101	N - 10	44	SA7189101	T3 - 1	58	SB1041001	B - 46	4	SB4357001	C1 - 35	6
SA5289001	N - 2	44	SA7191001	Ga	69	SB1086001	G - 4	28	SB4358001	C1 - 43	6
SA5290001	T1 - 2	54	SA7193001	T3 - 22	58	SB1200101	P - 9	46	SB4359001	C1 - 44	6
SA5291101	C6 - 2	16	SA7197101	T1 - 9	54	SB1229001	M2 - 5+	42	SB4360001	C1 - 41	6
SA5294001	F - 7	26	SA7199001	T1 - 21	54	SB1253001	H - 31	30	SB4361001	C1 - 48	6
SA5300001	D1 - 51	18	SA7385001	C6 - 16	16	SB1277001	A - 6	2	SB4362001	C1 - 45	6
SA5301001	D1 - 53	18	SA7460001	T3 - 36	58	SB1505001	Z - 12	62	SB4363001	C1 - 46	6
SA5339101	F - 55	26	SA7500001	T1 - 1	54		Wa	66	SB4365101	C1 - 47	6
SA5415001	C6 - 17	16	SA7588001	N - 7	44	SB1543002	Z - 11	62	SB4366001	C1 - 34	6
SA5559101	T2 - 1	56	SA7704001	D1 - 4	18	SB1565001	R - 1	50	SB4367001	C4 - 11	12
SA5593001	C1 - 7	6	SA7944101	Sp	67	SB2097001	B - 44	4	SB4368001	C4 - 10	12
	D2 - 1	20	SA8057001	K - 11	36	SB2131001	C4 - 40	12	SB4369001	C5 - 14	14
SA5829001	C6 - 4	16	SA8197101	Sp	67	SB2356001	Z - 61	62	SB4370001	C5 - 13	14
SA6038001	R - 2	50	SA8560001	C2 - 3	8	SB2439001	J - 49	34	SB4371001	C5 - 12	14
SA6087001	F - 18	26	SA8679001	A - 13	2	SB2456001	A - 14	2	SB4372001	C3 - 20	10
SA6182001	B - 19	4	SA8684001	D1 - 40	18		T3 - 33	58	SB4373001	C4 - 48	12
SA6207001	A - 24	2	SA8689001	D1 - 43	18	SB3511001	E - 26	24	SB4374001	C4 - 21	12
SA6210001	D2 - 42	20	SA8691001	G - 17	28	SB3847001	J - 56	34	SB4375001	C4 - 20	12
	D3 - 20	22	SA8707001	E - 45	24		J - 63	34	SB4376001	C4 - 23	12
SA6261002	Z - 68	64	SA9004001	B - 49	4	SB3848001	C1 - 38	6	SB4377001	C4 - 27	12
SA6272001	A - 21	2	SA9058001	Sp	68		C1 - 51	6	SB4378001	K - 8	36
SA6273101	J - 61	34	SA9191001	E - 30	24		D2 - 30	20	SB4379001	K - 5	36
SA6308001	C1 - 54	6	SA9207001	G - 19	28		D3 - 12	22	SB4380001	L - 9	38
SA6358101	C1 - 42	6	SA9396001	E - 21	24		K - 10	36	SB4381001	D2 - 2	20
SA6362001	T3 - 20	58	SA9397001	E - 23	24		T3 - 40	58	SB4382001	D2 - 20	20
SA6373001	T3 - 8	58	SA9500201	M1 - 4	40	SB3849001	C4 - 36	12		D3 - 2	22
SA6391001	G - 3	28	SA9535001	M2 - 2+	42		C4 - 50	12	SB4383001	Z - 4	62
SA6397001	J - 53	34	SA9559001	M1 - 14	40		C5 - 42	14	SB4384001	A - 30	2
SA6398001	J - 53	34	SA9564001	M1 - 15	40		L - 14	38	SB4385001	A - 29	2
SA6405001	N - 14	44	SA9565001	M1 - 16	40	SB4037001	F - 57	26	SB4387001	F - 46	26
SA6405002	N - 16	44	SA9602101	M1 - 5	40	SB4096001	P - 14	46	SB4388001	F - 47	26
SA6406001	N - 15	44	SA9616001	M2 - 1+	42	SB4155001	F - 3	26	SB4389001	H - 1	30
SA6406002	N - 17	44	SA9725001	M1 - 13	40		J - 12	32	SB4392001	E - 27	24
SA6407001	N - 18	44		Wa	65		L - 11	38	SB4394001	J - 46	32
SA6448301	Sp	67	SA9793001	E - 24	24		P - 17	46	SB4395001	J - 40	32
SA6450101	C3 - 12	10		F - 54	26	SB4183001	C2 - 1	8	SB4396001	J - 45	32
	C3 - 24	10	SA9826001	A - 40	2	SB4184001	C1 - 9	6	SB4397001	J - 32	32
SA6451101	C3 - 13	10		Wa	65	SB4185301	C1 - 6	6	SB4398001	J - 38	32
	C3 - 25	10	SA9831001	M2 - 1+	42	SB4186201	C1 - 2	6	SB4399001	J - 35	32
SA6576001	F - 17	26	SA9893001	M1 - 9	40	SB4259001	P - 11	46	SB4400001	J - 44	32
	F - 59	26	SA9914001	M2 - 7	42	SB4260001	P - 5	46	SB4401001	J - 24	32
SA6580001	F - 15	26		Wa	65	SB4261001	P - 12	46	SB4402001	C1 - 10	6
SA6593001	F - 14	26	SA9957001	A - 42	2	SB4275001	C3 - 7	10	SB4403001	Z - 2	62
SA6594001	C2 - 11	8		C1 - 55	6	SB4276001	C3 - 19	10	SB4404001	C4 - 2	12
SA6595001	C6 - 13	16		Wa	65	SB4277001	D2 - 22	20		C5 - 2	14

CODE	REF.NO	Page	CODE	REF.NO	Page	CODE	REF.NO	Page	CODE	REF.NO	Page
SB4405001	E - 11	24									
SB4406001	C1 - 14	6									
	C1 - 25	6									
SB4407001	C2 - 6	8									
SB4408001	C2 - 7	8									
SB4409001	C2 - 8	8									
SB4412001	Z - 1	62									
SB4413001	A - 27	2									
SB4414001	C4 - 18	12									
SB4415001	J - 33	32									
SB4416001	J - 21	32									
SB4420001	C4 - 34	12									
SB4421001	C4 - 24	12									
SB4422001	C4 - 25	12									
SB4423001	D2 - 5	20									
SB4424001	D2 - 4	20									
SB4430001	C1 - 5	6									
SB4431001	C1 - 28	6									
SB4432001	C1 - 11	6									
SB4433001	C4 - 1	12									
SB4453001	C4 - 42	12									
SB4454001	C5 - 1	14									
SB4455001	C5 - 31	14									
SB4456001	C5 - 36	14									
SB4457001	C4 - 47	12									
SB4458001	C3 - 6	10									
SB4459001	C3 - 18	10									
SB4460001	C5 - 44	14									
SB4461001	C5 - 45	14									
SB4464101	E - 28	24									
SB4467001	L - 1	38									
SB4468001	F - 41	26									
SB4469001	C1 - 24	6									
SB4508101	E - 13	24									
SB4509001	E - 14	24									
SB4516001	Z - 57	62									
SB4517001	Z - 56	62									
SB4524001	F - 23	26									
SB4525001	C4 - 53	12									
	C5 - 47	14									
SB4540101	M1 - 1	40									
SB4541001	M1 - 2	40									
SB4546101	Q - 2	48									
SB4547001	Q - 3	48									
SB4549001	Q - 4	48									
SB4570001	F - 56	26									
SB4573001	S - 4	52									
SB4595001	J - 48	34									
SB4689201	C1 - 53	6									
SB4713001	C6 - 18	16									
XD1115051	S - 6	52									

brother®

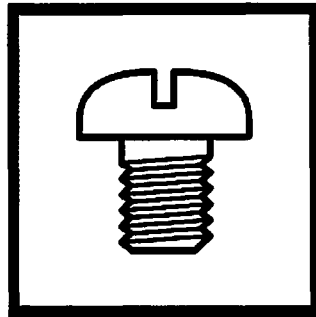

パーツブック  
PARTS BOOK

**ブラザー工業株式会社** <http://www.brother.co.jp/>  
〒448-0803 刈谷市野田町北地藏山1番地5 TEL:0120-33-2392  
**BROTHER INDUSTRIES, LTD.** <http://www.brother.com/>  
1-5, Kitajizoyama, Noda-cho, Kariya 448-0803, Japan. Phone : 81-566-95-0088

© 2013 Brother Industries, Ltd. All Rights Reserved.

BAS-311H  
SB4718-001.J/E  
2013.08.B (1)